

Raychem Terminations for Polymeric and MIND  
Paper Insulated Cables from 7.2 kV up to 36 kV

**Raychem**  
from TE Connectivity

# Termination systems designer

This worksheet enables you to arrive at a part number for a Raychem termination EPKT.  
Choose one figure from the left-hand column of each table.

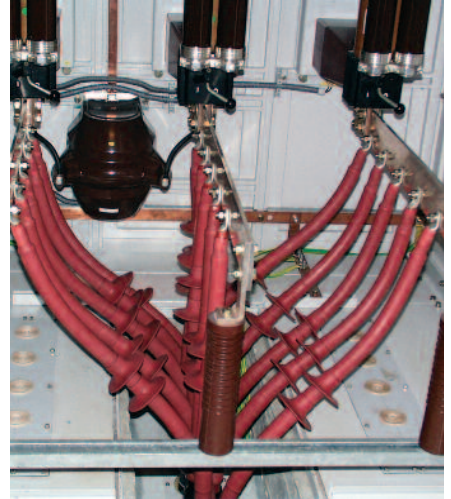

**Typical part number:**

EPKT- 17C3MOH3 B21 G43



**Voltage in kV**

<b>7</b>	for 7.2 kV
<b>17</b>	for 12 kV & 17.5 kV
<b>24</b>	for 24 kV
<b>36</b>	for 36 kV

Size in mm <sup>2</sup>	7.2 kV	12 kV & 17.5 kV	24 kV	36 kV
<b>A</b>	16 - 50	16 - 25	-	-
<b>B</b>	70 - 120	35 - 70	25 - 50	-
<b>C</b>	150 - 240	95 - 240	70 - 185	50 - 95
<b>D</b>	300 - 500	300 - 400	240 - 300	120 - 185
<b>E</b>	630 - 1000	500 - 800	400 - 630	240 - 500
<b>F</b>	-	1000	800 - 1000	630 - 1000

**No. of Cores**

<b>1</b>	for single (1) core
<b>3</b>	for three (3) core

**Dielectric**

**of insulation type**

<b>X</b>	for PLASTIC eg. XLPE, EPDM, EPR, etc.
<b>M</b>	for MIND non-draining paper (not applicable for draining paper cables)

**Location**

**of the termination**

<b>I</b>	for INDOOR
<b>O</b>	for OUTDOOR

**Length (only 3-core)**

**of the terminated portion (tail)**

<b>H1</b>	for 450 mm long
<b>H2</b>	for 650 mm long (min for 17.5 kV outdoor & 36 kV indoor)
<b>H3</b>	for 800 mm long (min for 24 kV outdoor & 36 kV outdoor)
<b>H4</b>	for 1200 mm long

### Armour earthing

Wire armour in paper or plastic cables can be effectively terminated to earth by means of mechanical clamping rings. Heat-shrinkable tubing for corrosion protection and an insulated copper conductor for earth connection are also included.

The kits can be ordered separately or with the termination by adding the mod code to the end of the part number.

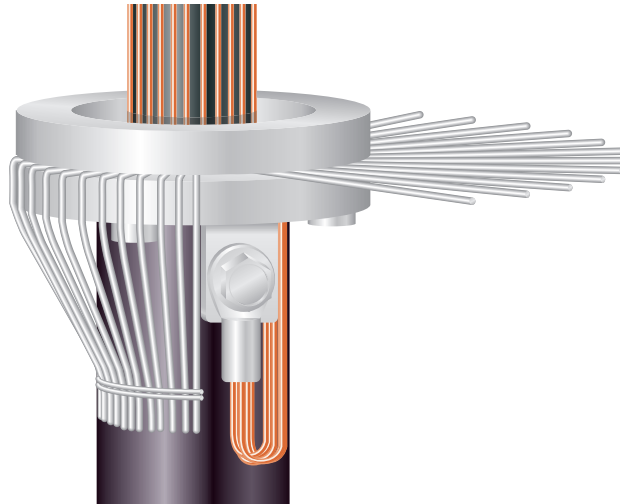

#### 1-core cables

Diameter Range (mm)	Application Range (mm <sup>2</sup> )					Part Number	Mod Code
	7.2 kV	12 kV	17.5 kV	24 kV	36 kV		
21 - 32	16 - 70	16 - 70	16 - 50	16 - 50	-	EAKT 1636	G 36
33 - 50	95 - 400	95 - 400	70 - 400	70 - 300	16 - 185	EAKT 1637	G 37
51 - 67	500 - 800	500 - 800	500 - 800	400 - 800	240 - 630	EAKT 1638	G 38

#### 3-core cables

Diameter Range (mm)	Application Range (mm <sup>2</sup> )					Part Number	Mod Code
	7.2 kV	12 kV	17.5 kV	24 kV	36 kV		
40 - 67	16 - 120	16 - 120	16 - 95	16 - 35	16 - 25	EAKT 1642	G 42
50 - 86	150 - 240	150 - 240	120 - 185	50 - 120	35 - 95	EAKT 1643	G 43
60 - 94	300 - 400	300 - 400	240 - 300	150 - 185	120 - 185	EAKT 1644	G 44
70 - 110	-	-	-	240 - 300	240 - 300	EAKT 1645	G 45

### Cable preparation kit

Two types of cable preparation kits are also available. The one for paper cable contains cleaning solvent, solder and binding wire.

The one for plastic cable contains abrasive paper, string, cleaning tissues and plastic gloves. These can only be ordered along with terminations by adding the mod code to the end of the part number.

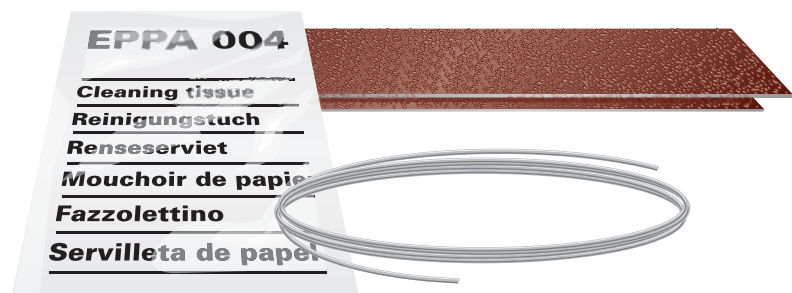

Application	Mod Code
Paper cable	E 01
Plastic cable	E 02

### Cable glands

The Raychem cable gland is used with a wide range of cable boxes designed for compound filling where the distance from bushing to base-plate is a limiting factor. The gland is made to match stud spacings to BS 2562.

It is also available with an insulating plate for separate earthing and of aluminium for single core applications. These can be ordered separately as complete kits or along with the termination by adding the mod code at the end of the part number.

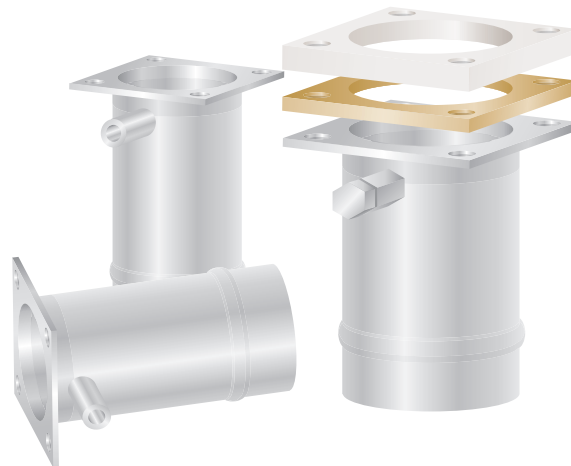

Application	Part Number	Mod Code
Steel/Small/X-Type/cables up to 95 mm <sup>2</sup>	EAKT 1605	G 05
Steel/Large/Y-Type/cables up to 300 mm <sup>2</sup>	EAKT 1606	G 06
Steel/Large/Y-Type/with insulating plate	EAKT 1607	G 07
Aluminium/Small/X-Type/1-core application	EAKT 1608	G 08

**Note:**

The stud hole spacing in the small gland is 66 mm x 66 mm and in the large gland is 86 mm x 95 mm.

### Solderless earth connection

Copper tape screens on plastic cables can be earthed mechanically by using Raychem’s solderless earth connection system. The kit comes complete with a tinned copper earthing braid and a mechanical roll spring for each phase.

These can be ordered separately as kits or with the termination by adding the mod code to the end of the part number.

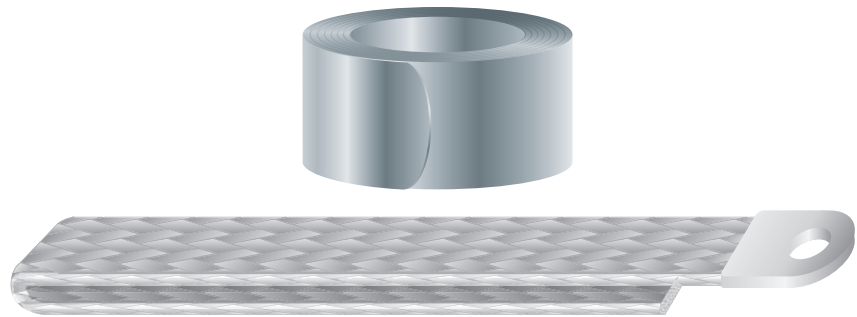

Diameter over Screen (mm)	Application Range (mm <sup>2</sup> )					Part Number	Mod Code
	7.2 kV	12 kV	17.5 kV	24 kV	36 kV		
12 - 18	16 - 50	16 - 50	16 - 25	-	-	EAKT 1655	G 55
19 - 24	70 - 150	70 - 150	35 - 95	25 - 70	25 - 35	EAKT 1656	G 56
25 - 30	185 - 300	185 - 240	120 - 185	95 - 150	50 - 70	EAKT 1657	G 57
31 - 44	400 - 630	300 - 630	240 - 500	185 - 500	95 - 300	EAKT 1658	G 58
41 - 65	800 - 1000	800 - 1000	630 - 1000	630 - 1000	400 - 1000	EAKT 1659	G 59

**Note:**

Solderless earth connections are also available for lead sheaths on paper cables. For such requirements please contact your local sales representative.

### Boots

Insulating boots are moulded parts which are shrunk over the connection between the cable lug and bushing to insulate them. They are used in switchgear and transformers with compound filled boxes where the clearances are insufficient for operation in air or to protect against flash over due to rodents or extreme humidity.

A full range of insulating boots are available up to 17.5 kV. These can be ordered separately by quoting the part number or with the termination by adding a mod code to the end.

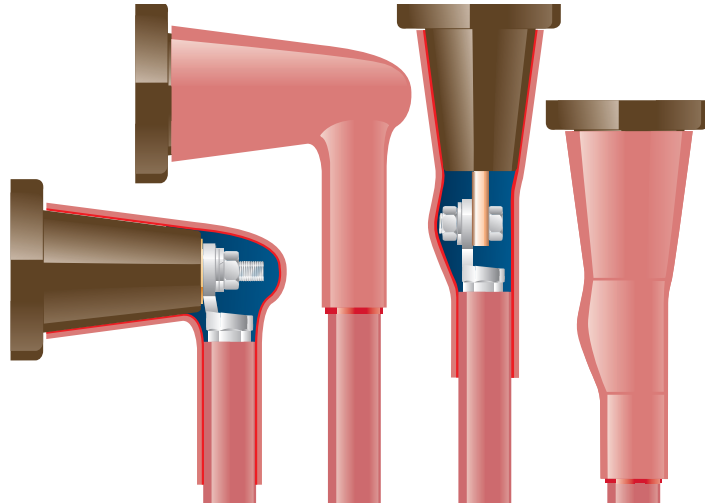

**Example:**

EPKT-17C3MOH3-B07

This kit comes complete with straight boots.

Application range	Straight boots		Right angle boots - long		Right angle boots - short	
	Mod Code	Part Number	Mod Code	Part Number	Mod Code	Part Number
10 - 35 mm <sup>2</sup>	B05	RSRB 4022	B08	RSRB 4042	B15	RSRB 4062
50 - 95 mm <sup>2</sup>	B06	RSRB 4024	B09	RSRB 4044	B16	RSRB 4064
120 - 300 mm <sup>2</sup>	B07	RSRB 4026	B10	RSRB 4046	B17	RSRB 4066

**Note:**

1. Long boots are 110 mm long over the bushing. The short boots are 90 mm long.
2. Insulating boot kits are also available for up to 36 kV applications.  
For such requirements please refer to your local sales representative.

### Support insulators and bracket

We also manufacture a range of hybrid insulators. The sheds of red, non tracking, flexible polymeric material are mounted on a porcelain core. Sets of three, along with a galvanised steel T-bracket, can be ordered for applications up to 36 kV either as separate kits by quoting the part number or with the termination by adding the mod code to the end.

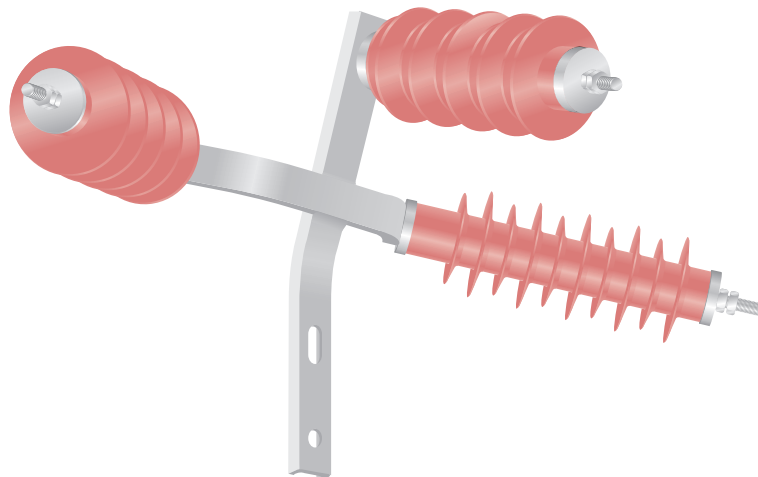

Reference standard IEC 60815, IEC 60071

Part Number	Mod Code	Description (pollution level IV)	(pollution level III)	(pollution level II)	(pollution level I)
EAKT 1521	B 21	Insulator Kits 12 kV		Insulator Kits 17.5 kV	Insulator Kits 24 kV
EAKT 1523	B 23	Insulator Kits 17.5 kV	Insulator Kits 24 kV		Insulator Kits 36 kV
EAKT 1524	B 24	Insulator Kits 24 kV Insulator Kits 36 kV			

**Note:**

The voltage is the highest phase-to-phase voltage  $U_{max}$

## Raychem insulated adapter termination system RICS for SF<sub>6</sub>-insulated switchgear up to 24 kV

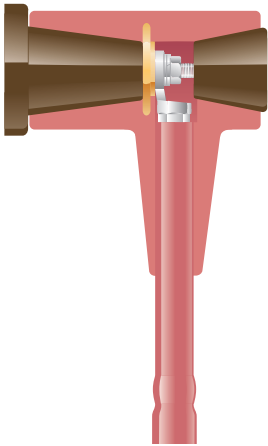

T-adapter for perpendicular connection of the termination to SF<sub>6</sub>-insulated switchgear

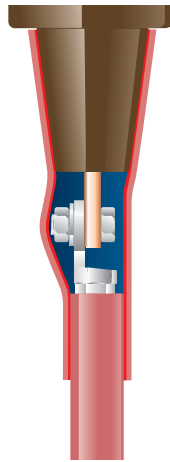

T-adapter for perpendicular connection of termination and surge arrester to SF<sub>6</sub>-insulated switchgear

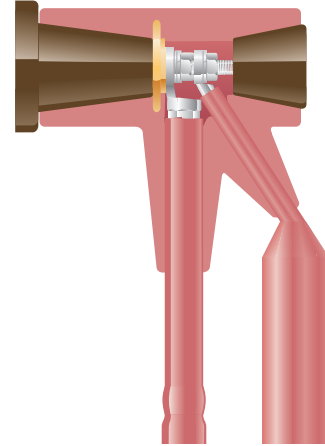

Straight adapter for vertical connection of the termination to SF<sub>6</sub>-insulated switchgear

### T-adapter

The insulated adapter termination system provides perfect sealing, electrical insulation and an electrical connection between Raychem terminations and SF<sub>6</sub>-insulated switchgear up to 24 kV.

Its lead-in insulator (630 A) conforms to DIN 47636 and ANSI IEEE 386.

The cable box of the switchgear must be provided with suitable protection against electric shock. The insulating adapter is compatible with all Raychem terminations. Details of the terminations can be found in the cable accessories catalogue.

The insulating body, fixing bolts, terminal stud and backplug are supplied in a 3-phase set complete with installation instruction. Cable lugs and terminations are not included. For double T-connections, the second adapter is of special design and includes connection plug, insulating body, fixing bolts, terminal stud and backplug. It can be combined with first Raychem adapters of type RICS-57x3-CU with M16 lugs, but not with Raychem adapter for surge arresters type RICS-51x9.

### T-adapter with surge arrester

Thick walled insulator made of high quality elastomer with sealing face over the termination, bushing cone and plug.

The electrical connection is made with a terminal stud and the cable lug of the termination. Two cable connection is possible. A special plug which allows cable testing without disconnecting the adapter is also offered. The design of the adapter for connecting the surge arrester is basically identical. The elastomer insulator has an additional lead-in duct for the surge arrester. Details of the surge arresters can be found in the brochure EPP 0533.

Scope of supply (for three phases)  
Insulator, plug, terminal stud, small accessories and installation instructions.

### Straight adapter

A thick walled, heat-shrinkable insulating sleeve provides a hermetic seal over the cone of the bushing and the termination. The adapter area is smoothed with a meltable filler strip.

Scope of supply (for three phases)  
Heat-shrinkable insulating sleeving, filler strip, small accessories and installation instructions. Terminal stud and lug must be enclosed.

## Raychem insulated adapter termination system RICS for SF<sub>6</sub>-insulated switchgear up to 24 kV

### Raychem RICS T-adapter

Voltage class (U <sub>0</sub> / U (Um)kV)	Cable type	Application range (mm <sup>2</sup> )	Type of indoor termination	Part Number
6.35 / 11 (12)kV	Polymeric 1C & 3C	25 to 50	IXSU-F, POLT, EPKT, TFTI	RICS 5113
		70 to 150		RICS 5123
		185 to 240		RICS 5133
		300		RICS 5143
8.7 / 15 (17,5)kV	Polymeric 1C & 3C	25 to 35	IXSU-F, POLT, EPKT, TFTI	RICS 5113
		50 to 95		RICS 5123
		120 to 185		RICS 5133
		240 to 300		RICS 5143
12.7 / 22 (24)kV	Polymeric 1C & 3C	10 to 70	IXSU-F, POLT, EPKT, TFTI	RICS 5123
		95 to 185		RICS 5133
		240 to 300		RICS 5143
6.35 / 11 (12)kV	Paper (MI and MIND) Belted	35	EPKT-45xx	RICS 5113
		50 to 95		RICS 5123
		120 to 185		RICS 5133
		240		RICS 5143
6.35 / 11 (12)kV	Paper (MI and MIND) Screened or belted	35 to 70	EPKT	RICS 5113
		95 to 150		RICS 5123
		185 to 240		RICS 5133
		300		RICS 5143

### Raychem RICS T-adapter with Surge Arrester

Voltage class (U <sub>0</sub> / U (Um)kV)	Cable type	Application range (mm <sup>2</sup> )	Type of indoor termination	Part Number
6.35 / 11 (12)kV	Polymeric 1C & 3C	NA	IXSU-F, POLT, EPKT, TFTI	
		NA		
		185 to 240		RICS 5139
		300		RICS 5149
8.7 / 15 (17,5)kV	Polymeric 1C & 3C	NA	IXSU-F, POLT, EPKT, TFTI	
		NA		
		120 to 185		RICS 5139
		240 to 300		RICS 5149
12.7 / 22 (24)kV	Polymeric 1C & 3C	NA	IXSU-F, POLT, EPKT, TFTI	
		95 to 185		RICS 5139
		240 to 300		RICS 5149
6.35 / 11 (12)kV	Paper (MI and MIND) Belted	NA	EPKT-45xx	
		NA		
		120 to 185		RICS 5139
		240		RICS 5149
6.35 / 11 (12)kV	Paper (MI and MIND) Screened or belted	NA	EPKT	
		NA		
		185 to 240		RICS 5139
		300		RICS 5149

### Tests

The adapters meet Cenelec HD629.1S1, IEC 540, VDE 0278 and ANSI IEEE 386 standards, as well as the Raychem specification PPS 3013, in addition they were type tested together with most switchgear. The test requirements and results are summarised in Raychem test reports, which are available on request.

## Raychem elastomeric insulating bushing boot RCAB for bushings up to 17.5 kV and 24 kV

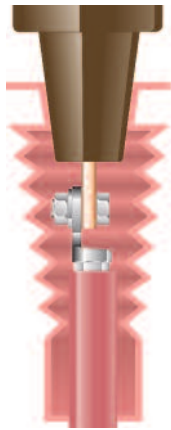

Raychem right angle or inline application RCAB up to 17.5 kV

Raychem elastomeric insulating boots are moulded parts which fit over the connection between the cable lug and the inline or right-angled equipment bushing to improve phase-to-phase and phase-to-ground insulation. They are used in switchgear and transformer cable boxes where the air clearances are insufficient for normal operation, or to protect against flashover due to rodents or high humidity. The non-tracking elastomeric housing has excellent erosion resistance, dielectric properties and environmental resistance, giving superb performance in areas of high humidity and electrical stress.

### Raychem adapter RCAB

Voltage class (U <sub>0</sub> / U (Um)kV)	Cable type	Application range (mm <sup>2</sup> )	Type of indoor termination	Part Number
6.35 / 11 (12)kV	Polymeric 1C & 3C	35 to 300	IXSU-F, POLT, EPKT, TFTI	RCAB 4120
12.7 / 22 (24)kV	Polymeric 1C & 3C	50 to 300	IXSU-F, POLT, EPKT, TFTI	RACB 5120

### Tests

The adapters meet Cenelec HD629.1S1, IEC 540, VDE 0278 and ANSI IEEE 386 standards, as well as the Raychem

specification PPS 3013, in addition they were type tested together with most switchgear. The test requirements and

results are summarised in Raychem test reports, which are available on request.

While TE Connectivity (TE) has made every reasonable effort to ensure the accuracy of the information in this catalog, TE does not guarantee that it is error-free, nor does TE make any other representation, warranty or guarantee that the information is accurate, correct, reliable or current. TE reserves the right to make any adjustments to the information contained herein at any time without notice. TE expressly disclaims all implied warranties regarding the information contained herein, including, but not limited to, any implied warranties of merchantability or fitness for a particular purpose. The dimensions in this catalog are for reference purposes only and are subject to change without notice. Specifications are subject to change without notice. Consult TE for the latest dimensions and design specifications. Raychem, TE Connectivity and TE Connectivity (logo) are trademarks. Other logos, product and company names mentioned herein may be trademarks of their respective owners.

**TE Energy - innovative and economical solutions for the electrical power industry: cable accessories, connectors & fittings, insulators & insulation, surge arresters, switching equipment, street lighting, power measurement and control.**

Tyco Electronics Raychem GmbH  
 a TE Connectivity Ltd. Company  
 TE Energy  
 Finsinger Feld 1  
 85521 Ottobrunn/Munich, Germany

Phone: +49-89-6089-0  
 Fax: +49-89-6096345

energy.te.com

