



# PANTHER TAILS™



The **Balmoral™** Panther Tails™ are designed to cover Power Lines and Wires to provide electrical insulation from brush contact and mechanical protection. Black colour blends into the native environment. They are suitable for live works and maintenance activities, Panther Tails are ideal for tree protection and as a preventative measure for wildlife on Power Lines.

## Specifications

Item No	Length (~m)	Diameter (~mm)	Thickness (~mm)	Colour	Material	Coupling	Weight
TPP15	60	15	2.2	Yellow inner Black outer	EVA	NA	~9kg/60m-roll
TPP20	3	20	2.2	Yellow inner Black outer	PE	Male to Female Interlock	~800g/length



TPP20

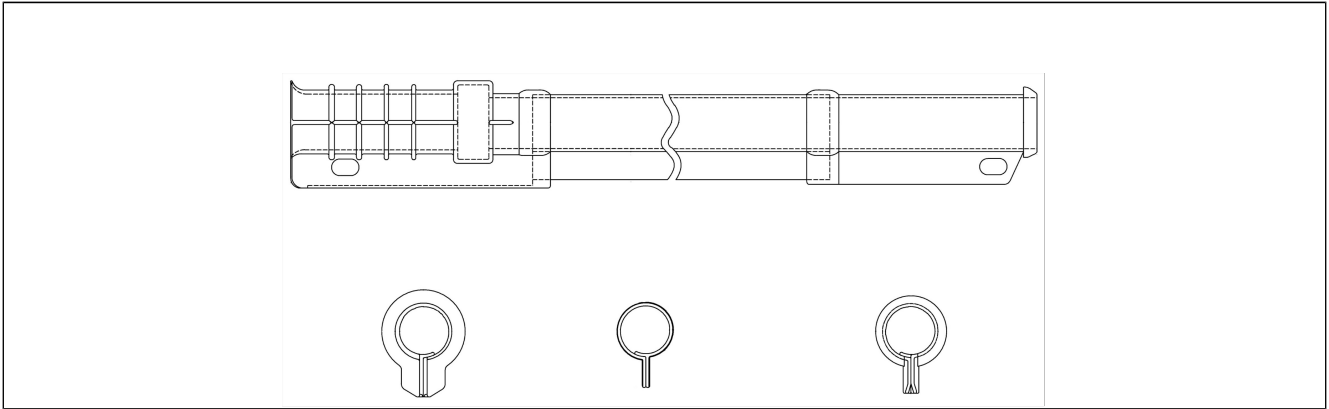

TPP35	3	35	2.2	Yellow inner Black outer	PE	Male to Female Interlock	~1.8kg/length
-------	---	----	-----	-----------------------------	----	--------------------------------	---------------



**Materials:**

Two layer construction with black outer high abrasion layer

**Conforms with the electrical requirements of:**

Class2  
ASTM F712 14.6kv (both phases covered)  
AS4202 650V

**Weathering:**

Excellent weathering & UV resistance  
 TPP15 accelerated UV testing 1000 hours equivalent to 5 years\*  
 TPP20 + TPP35 accelerated UV testing 2000 hours equivalent to 10 years\*  
 \*Environmental conditions in Japan  
 - 20 degrees C, no sign of damage

**Abrasion Resistance:**

No puncture after 500 rotations at 24.5N (with yellow layer exposed).

**For further product information - Visit our website:**

[www.balmoralengineering.com](http://www.balmoralengineering.com)

Disclaimer: ROTAMARKA, LION TAILS, TIGER TAILS, PANTHER TAILS and BALMORAL ENGINEERING are trade marks owned by Balmoral Engineering Pty Ltd. The information in this document or product specification is believed to be correct as of the date of issue and is subject to change without notice. Results and output data herein are indicative of lab testing protocols and may vary in field applications or environments. BALMORAL ENGINEERING makes no guarantees, expressed or implied as to the merchantability or fitness for purpose. The products are only to be used and installed by industry certified personnel. If applicable, maximum test speeds should be endured by the Products for a limited time period no greater than those described in the lab protocols. Performance of the device in extreme weather events or harsh environments is not warranted. If BALMORAL ENGINEERING sells any component of a product or kit, we make no representations or guarantees as to the serviceability of the actual product or kit into which the component is being added. Furthermore, it is recommended that any such addition to the kit is done by BALMORAL ENGINEERING. In relation to the Balmoral Engineering ROTAMARKA™ series of products, it should be noted that not all visual responses to the device are going to be similar or alike. As such, no guarantees can be given as to the Products effectiveness. Given the variety of factors that can affect the use and application of a product, some of which are within the user's knowledge and control, it is essential that the user evaluate the product to determine whether it is fit for a particular purpose and suitable for the user's method of use or application. The purpose of this document is to provide a description of the product and/or guidance to the installation thereof. When installing Balmoral Engineering products, due consideration must be given to the user's training and practice methodologies including any requirements of the entity who owns the infrastructure onto which the BALMORAL ENGINEERING Product is being installed. This must take precedence over any guidance BALMORAL ENGINEERING may provide. Notwithstanding, that all the above guidelines are followed, the ultimate responsibility for installing and maintaining the product correctly is with the end user. As service environments may differ markedly with each application, the level of care required may change and is solely the responsibility of the end user. The above data sheet is provided as an estimate of performance and life and is not a guarantee or warranty. © 2020, All Rights Reserved, Balmoral Engineering Pty Ltd.  
 \*Product images displayed are representative only\*