

ECOPILLAR - EP9

- COMPACT SERVICE PILLAR, UP TO 7 FUSES

Designed and made right here in New Zealand, the ECOpillar EP9 is a compact yet functional distribution pillar. Built from Rotathene 6329 UV stable plastic, the EP9 will take the knocks and come back for more. It's designed specifically for customers who demand safety, performance and unobtrusive good looks from their electrical reticulation systems. Internally, all components are industry standard and fit perfectly.

The EP9 has a compact installation footprint and flat sides making it perfect for locating close to fences. The contoured design with no sharp edges, can be ordered in a range of colours on request. This is an integrated system, designed by people in the industry for people in the industry.

FEATURES

- 7 way fuse panel
- Removable Fuse Rack
- Customise with your company logo (conditions apply)
- Can be secured to concrete base
- Removing the fuse panel rack creates a comfortable working space for cable connection below



DIMENSIONS

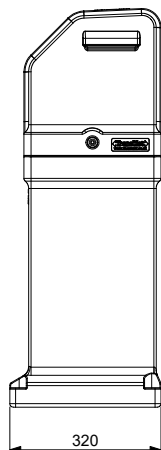
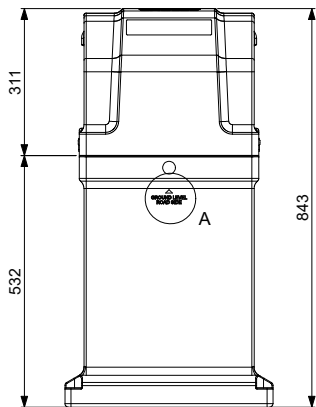
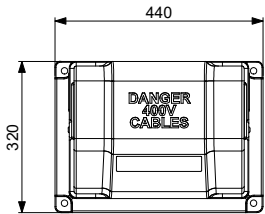

CUSTOMISATIONS AVAILABLE

- Lid details specific to your company's requirements
- Component kits based on usage requirements
- Alternate colours are available
- Lock can be fitted
- Locate Neutral bar at front or back of rack

APPLICATION OPTIONS (includes but not limited to)

