

Bowthorpe EMP LV/MV Outdoor Surge Arresters

Bowthorpe EMP LV/MV Surge Arresters for Outdoor Applications

Table of Contents

Product Classification	Voltage Range	Page
DA Series Distribution Metal Oxide Surge Arresters (Uc)		2
DA1 Metal Oxide Surge Arresters - Class 1	4-39 kV	3
DA1 Series Product Accessories		6
OCP Series Open Cage Polymeric Surge Arresters (Uc)		7
OCP1 Open Cage Polymeric Surge Arresters - Class 1	3-29 kV	8
OCP2 Open Cage Polymeric Surge Arresters - Class 2	3-41 kV	10
OCP Series Product Accessories		14
CLX Surge Arresters for Covered Conductors	12-36 kV	18
EGLA Externally Gapped Line Arrester		19
TVC Transient Voltage Clampers		20
SPG4 Spark Gap Surge Arresters	<1kV	21

DA Series Distribution Metal Oxide Surge Arresters

Bowthorpe EMP pioneered the development of polymeric composite housed surge arresters in the early 1980's and since then has a proven service experience across the globe, operating in the worlds toughest environments.

Bowthorpe EMP surge arresters provide active over voltage protection that contributes directly to improved reliability of your system, reducing lost minutes and protecting expensive assets.

Bowthorpe EMP DA silicone surge arresters have been designed and tested to meet our customers demands with reliability and offering improved operational performance. The DA development was based on more than 40 years of experience in arrester design and manufacture within TE Energy.

The DA series is tested and qualified as per IEC 60099-4 standards and all test reports are independently certified.

- 1) Proven moisture sealing technology
- 2) Non-tracking insulating silicone materials.
- 3) Fully integrated, single piece and void-less design.
- 4) Reliable earth lead disconnect
- 5) Safe mode of failure
- 6) Quality



Sealing

All arrester cores are encapsulated in silicone insulating housing. A permanent chemical bond connects the arrester core and the non-tracking silicone housing. This invisible interface prevents moisture from entering during severe thermal fluctuations due to normal climatic and energy absorption events.

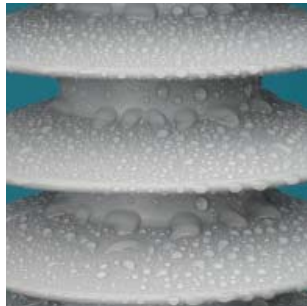

Polymer housing

Non-tracking and hydrophobic silicone insulating material is used for DA arrester housings. The DA surge arrester series is available with standard or extra creepage distance. The housing material has proven performance in long term TERT and UV aging tests and proven resistance to flammability.

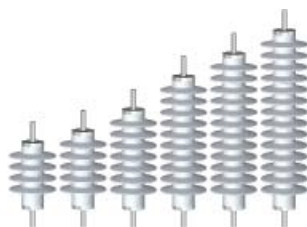

Integrated design

Manufacturing integrates all components in a single piece. There are no glued interfaces. The design is void and gap free ensuring peak performance under the harshest conditions.



Reliable and consistent ELD

Our robust earth lead disconnect, (ELD) offers operational reliability and consistency. It was designed to operate in event of arrester failure, removing earth connection and fault from line. It can be shipped and stored restriction free.

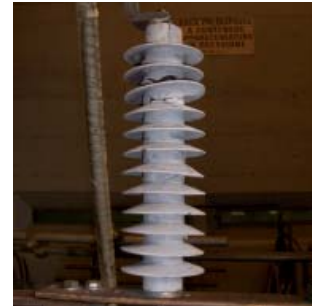

Safe mode of failure

Our high energy arresters are tested in accordance with the pre-failing mode of failure test in IEC 60099-4. This testing has proven the DA1 surge arrester series safe and predictable failure characteristics.



Quality

The DA series arrester is manufactured to international quality standards in TE Connectivity production facilities. We perform 100% routine testing on arresters:

- 1) Visual inspection
- 2) Reference voltage test
- 3) Partial discharge test

DA1 Metal Oxide Surge Arresters - Class 1

Qualification testing

Decades of insulating materials, arrester design and development experience has been combined to create the DA series arrester. The basic construction comprises of high energy ZnO varistors, assembled within a flame retardant composite laminate tube. The following design IEC 60099-4 design type tests have been carried out on the DA series arresters:

- 1) Insulation withstand tests on the arrester housing
- 2) Residual voltage tests
- 3) Long-duration current impulse withstand test
- 4) Operating duty tests
- 5) Short-circuit tests
- 6) Internal partial discharge tests
- 7) Test of the bending moment
- 8) Weather Ageing Test
- 9) Power -frequency voltage versus time characteristics on an arrester

The silicone insulating material has been designed and optimised for arrester application. The following additional testing was performed in the qualification of the silicone:

- 1) Tracking and Erosion
- 2) UV testing
- 3) Thermal endurance
- 4) Dielectric testing
- 5) Flammability testing.
- 6) Long term water immersion testing

Production and quality

All our arrester production facilities have implemented QC and QA procedures according to international standards to ensure test programs that guarantee quality conforming products. 100% of all Varistors are tested and stamped with unique varistor residual and reference voltage. The following tests are performed on varistors:

- 1) Residual voltage
- 2) Reference voltage
- 3) Leakage current
- 4) Physical examination to screen damaged varistors
- 5) LOT test: High current impulse test
- 6) LOT test: Aging test

At the end of the arrester assembly process, the following mandatory IEC tests are completed on every arrester:

- Visual inspection
- Reference voltage test
- PD testing.

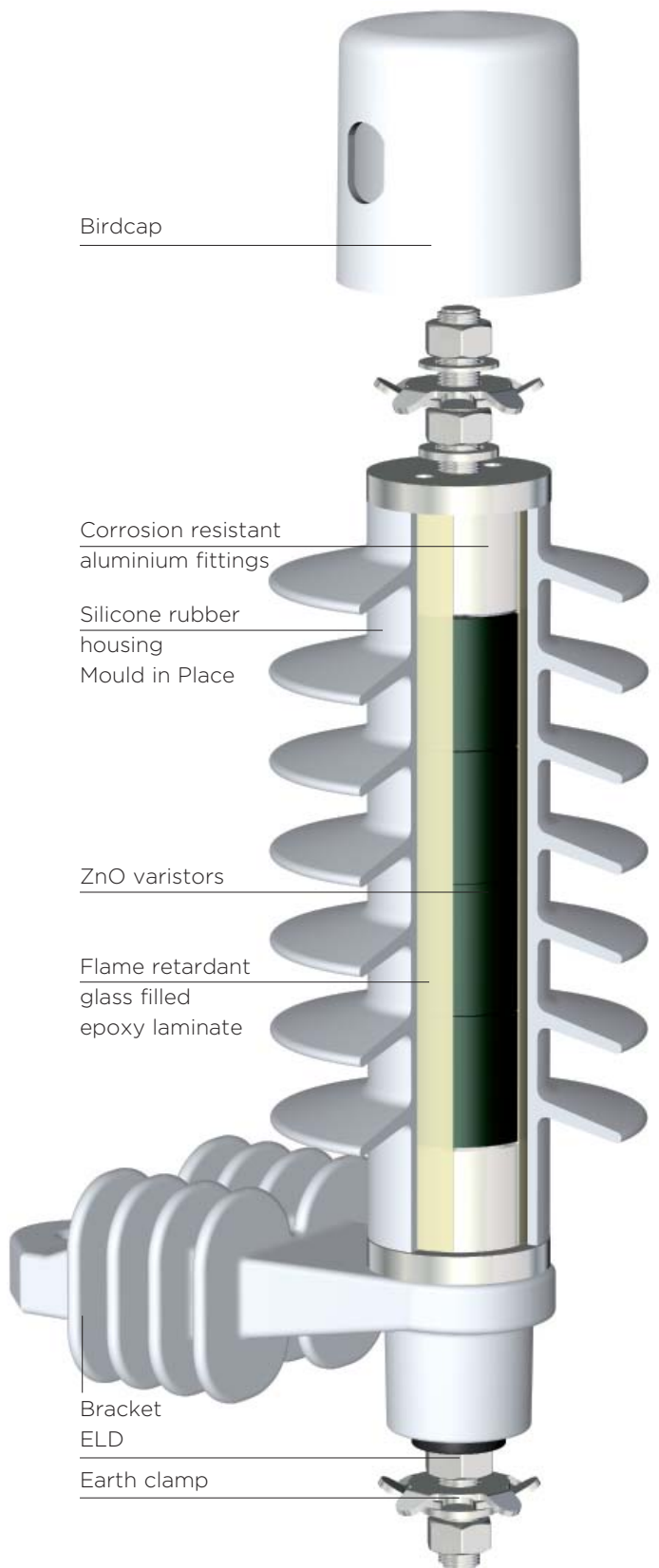

DA1 Metal Oxide Surge Arresters - Class 1

Application

Protection of MV networks and equipment from lightning and switching surge related over-voltages. Designed and optimised to protect distribution assets including transformers and cable-end terminations.

Generic technical data

DA1 series		4 - 39 kV
Rated discharge current (8/20µs)		10 kA
Line discharge class 1 according to		IEC 60099-4
Operating duty impulse withstand current (4/10µs)		100 kA
Long duration current impulse (2000µs)		325 A
10 second TOV, (UTOV / U _c)		1.29 * U _c
High current short circuit: (pre-failing method) (Safe non-shattering failure mode)		21 kA
Energy		5.6 kJ/kV
Service conditions	Ambient temperature	- 60°C to + 60°C

Benefits

- Tested in accordance with IEC60099-4 at independent accredited laboratories
- Direct moulded housing to prevent moisture ingress
- Low residual voltages
- High-energy handling
- Safe non-shattering short circuit behavior to higher current levels
- Maintenance free
- Hydrophobic silicone housing: (Tracking and erosion resistant)
- Excellent cantilever and tensile performance
- Quality design and manufacturing meeting international standards

TOV of DA1 with 100kA single shot high current prior energy

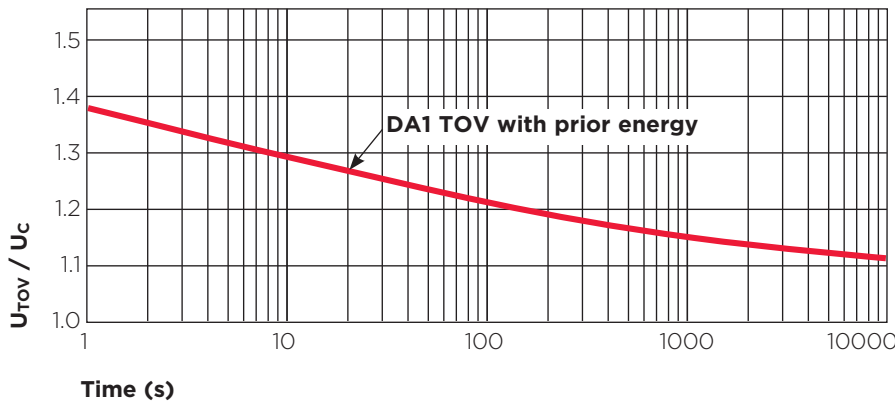

Temperature of samples (pre-heated): 60° C according to IEC 60099-4.
TOV Curve applies to an arrester which has a pre-stress applied prior to TOV verification. This pre-stress is equivalent to one high current impulse of 100kA, 4/10µs as per the operating duty test.

U_{TOV} = TOV withstand voltage;

U_c = continuous operating voltage

DA1 Metal Oxide Surge Arresters - Class 1

DA1 Standard electrical data

DA1	U continuous kV(r.m.s)	U rated kV(r.m.s)	U residual in kV when tested to the following impulse waveforms					
			Lightning (8/20µs)			Steep lightning (1/20µs)	Switching (30/60µs)	
			5kA	10kA	20kA	10kA	125A	500A
DA1-04	3.2	4	10	10.6	11.6	11.1	8	8.4
DA1-06	4.8	6	14.9	15.9	17.4	16.7	12	12.7
DA1-08	6.4	8	19.9	21.2	23.2	22.3	15.9	16.9
DA1-10	8	10	24.9	26.5	29.1	27.9	19.9	21.1
DA1-12	9.6	12	29.9	31.8	34.9	33.4	23.9	25.3
DA1-15	12	15	37.3	39.8	43.6	41.8	29.9	31.6
DA1-18	14.4	18	44.8	47.7	52.3	50.2	35.9	38
DA1-21	16.8	21	52.3	55.7	61	58.5	41.9	44.3
DA1-22	17.6	22	54.8	58.3	63.9	61.3	43.9	46.4
DA1-24	19.2	24	59.7	63.6	69.7	66.9	47.8	50.6
DA1-27	21.6	27	67.2	71.6	78.4	75.2	53.8	56.9
DA1-30	24	30	74.7	79.5	87.2	83.6	59.8	63.3
DA1-33	26.4	33	82.1	87.5	95.9	92	65.8	69.6
DA1-36	28.8	36	89.6	95.4	104.6	100.3	71.8	75.9
DA1-39	31.2	39	97.1	103.4	113.3	108.7	77.7	82.2

Uc: Continuous Voltage; Ur: Rated Voltage; Ures: Residual Voltage

DA1 Standard housing parameters

DA1-x	Sheds	Impulse voltage 1.2/50µs (kV)	Power frequency withstand voltage, wet (kV)	Flash over distance (mm)	Creepage length (mm)	Height L (mm)	Weight (approx) (kg)
A	4	134	50	152	329	147	1.2
B	5	160	56	177	404	172	1.4
C	7	194	66	227	553	222	1.8
D	8	205	75	252	627	247	2
F	10	247	102	302	776	297	2.6
G	12	273	122	352	925	347	2.9
H	14	295	135	402	1074	397	3.4

Housing and Ur compatibility

Ur	Housing code (M):	A	B	C	D	F	G	H
	Creepage:	329	404	553	627	776	925	1074
4		●	■					
6		●	■					
8		●	■	■				
10		●	■	■				
12		●	■	■	■			
15			●	■	■			
18			■	●	■	■		
21				●	●	■		
22				■	●	■	■	
24				■	■	■	■	
27					■	●	■	■
30					■	●	■	■
33						■	●	■
36							●	■
39							■	●

● standard housing ■ optional housing

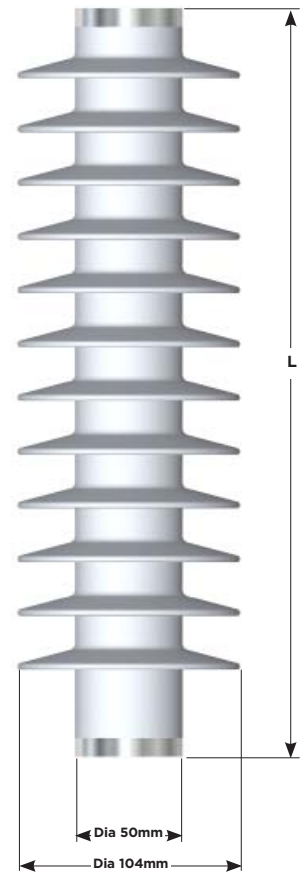

Notes:

Mechanical strength data

Cantilever	Nm	350
Tensile	kN	2
Torque	Nm	50

DA1 Product Accessories - Class 1



BOW-DA1-

Y	Y	M	-	1	2	3	4	5	6	-	P
---	---	---	---	---	---	---	---	---	---	---	---

Naming convention cross reference:

- DA1** = series type: DA1 for 10kA, class1 arrester.
- YY** = Ur see page 5
- M** = housing code see page 5

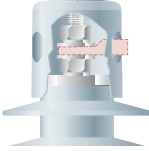
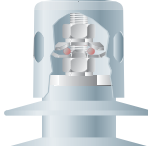
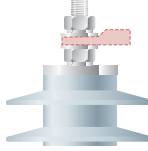
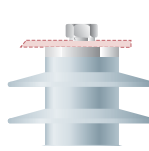
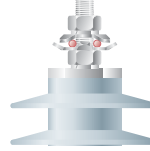
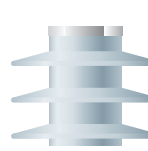
1 Line lead accessories

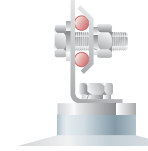
							
B xxxxx Birdcap with F accessory	E xxxxx Birdcap with M accessory	F xxxxx Exposed stud for lug connection	H xxxxx M12 Cap screw & spring washer	M xxxxx Exposed stud for line lead connection	O xxxxx No stud. No accessories	P xxxxx S-Clamp	Q xxxxx L-Clamp

2 Line lead options

x 0 xxxx No Line Lead Wire	x 4 xxxx 0.5m 35mm ² Copper Line Lead & one M12 lug
x 1 xxxx 0.5m 16mm ² Copper Line Lead & one M12 lug	x 5 xxxx 1m 35mm ² Copper Line Lead & one M12 lug
x 2 xxxx 1m 16mm ² Copper Line Lead & one M12 lug	x 6 xxxx 1m 35mm ² Copper Line Lead & no lug
x 3 xxxx 1m 16mm ² Copper Line Lead & no lug	

For addition lead options, please contact support team at: surgearresters@te.com

3 Earth lead accessories:

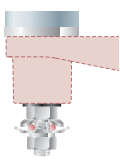
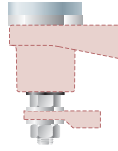
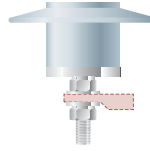
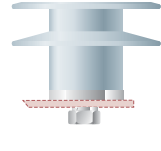
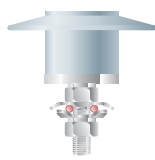
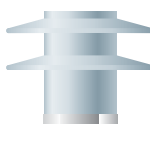
					
xx D xxx Disconnect + M accessory	xx E xxx Disconnect + F accessory	xx F xxx Exposed stud for lug connection	xx H xxx M12 Cap screw & spring washer	xx M xxx Exposed stud for line lead connection	xx O xxx No stud. No accessories

4 Earth lead options

xxx 0 xx No Earth Lead Wire	xxx 4 xx 0.5m 35mm ² Copper Earth Lead & one M12 lug
xxx 1 xx 0.5m 16mm ² Copper Earth Lead & one M12 lug	xxx 5 xx 1m 35mm ² Copper Earth Lead & one M12 lug
xxx 2 xx 1m 16mm ² Copper Earth Lead & one M12 lug	xxx 6 xx 1m 35mm ² Copper Earth Lead & no lug
xxx 3 xx 1m 16mm ² Copper Earth Lead & no lug	

For addition lead options, please contact support team at: surgearresters@te.com

5 Mounting brackets:

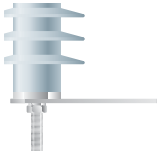
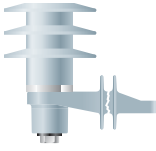
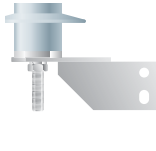
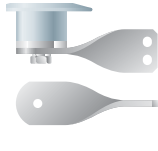
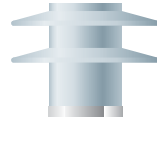
				
xxxx A x Straight 2 hole mounting bracket*	xxxx B x Insulating bracket*	xxxx C x DIN metal bracket, (stainless)*	xxxx E x DIN metal bracket, (galvanised)*	xxxx N x No mounting accessories

*only available in -I packaging option

6 Mounting bracket options:

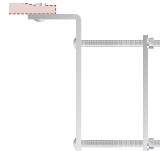
	
xxxxx 0 No option	xxxxx 1 NEMA Cross arm bracket

P Packaging

I	Individual Packing	(1 arrester per carton)
S	3 Pack	(3 arresters per carton)

Ordering example: BOW-DA1-12A-FOE0B0-I

All fastners M12 unless stated

OCP Series Open Cage Polymeric Surge Arresters

Bowthorpe EMP pioneered the development of polymeric housed surge arresters in the early 1980’s and has a proven service experience across the globe, operating in the worlds toughest environments.

Bowthorpe EMP “OCP” silicone surge arresters have been designed and tested to meet customers toughest environmental conditions and to meet the requirements of IEC60099-4.

Benefits

- Tested in accordance with IEC60099-4 at independent accredited laboratories
- Superior protection margins
- Direct molded housing to prevent moisture ingress
- Low residual voltages
- High-energy handling
- Superior TOV performance
- Safe non-shattering short circuit behavior to higher current levels
- Maintenance free
- Hydrophobic silicone housing: (Tracking and erosion resistant)
- Excellent cantilever and tensile performance
- Excellent mechanical, vibration and impact withstand capability
- Quality design and manufacturing, ISO 9001 and 14001 compliant

OCP series construction

At the core of the Bowthorpe EMP OCP design is our improved ZnO varistor disk, which has superior thermal and electrical characteristics and stability. The resulting new varistor and OCP design combination has resulted in superior energy handling and TOV performance. This superior thermal behavior yields products with:

- Excellent TOV performance.
- Safe, non-shattering failure in the short circuit test by pre-failing to higher fault currents.
- High energy handling capability.

The crimped structural construction ensures light weight product with optimal mechanical strength.

The manufacturing process ensures void free construction and optimum interface sealing. This is achieved by bonding the silicone housing directly to the ZnO discs and aluminium fittings using a TE Connectivity proprietary bonding solution.

OCP silicone hydrophobic features

- Alternating sheds for superior pollution flash over resistance
- Superior TERT performance
- Housing tested to IEC 1000hr salt fog test
- Constant voltage: 4.5kV, >360min
- Step voltage: >300min
- All eventual failures by erosion only, ie no tracking in voltage test

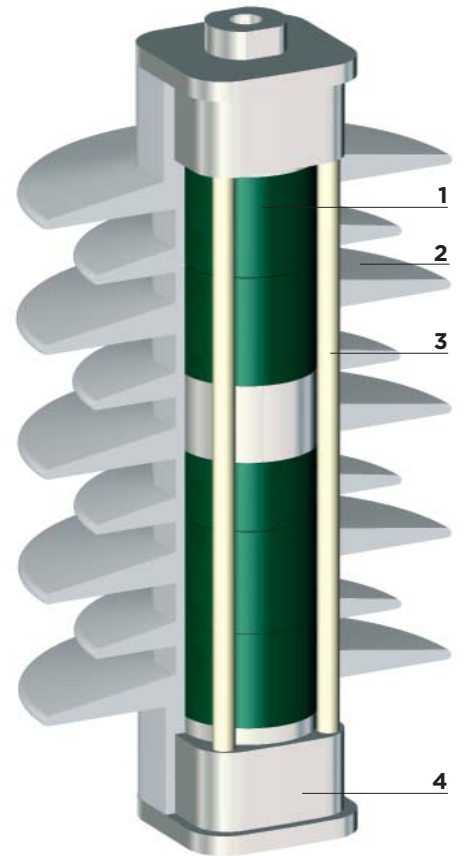

The construction of the OCP design comprises of:

- 1** ZnO, (Zinc Oxide) varistors
- 2** TE Connectivity proprietary silicone housing
- 3** Flame retardant FRP structure
- 4** Corrosion resistant aluminium fittings



Excellent hydrophobicity

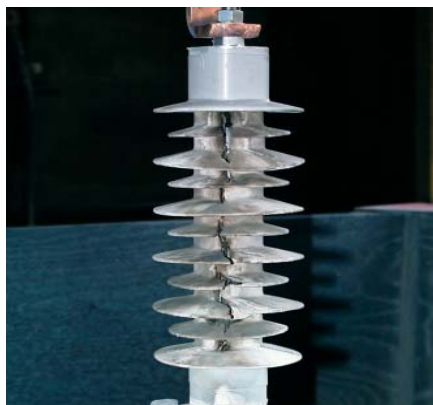

Safe short circuit failure



Superior TERT performance

OCP1 Open Cage Polymeric Surge Arresters - Class 1

Application

Protection of MV networks and equipment from lightning and switching surge related over-voltages in areas with relatively high iso-keraunic levels. Suitable for both outdoor and indoor use to protect transformers and cable end terminations.

Generic technical data

OCP1 S/L Series		3-29kV U _c
Rated discharge current (8/20µs)		10kA
Line discharge class 1 according to		IEC 60099-4
Operating duty impulse withstand current (4/10µs)		100kA
Long duration current impulse (2000µs)		350A
High current short circuit: (pre-failing method) (Safe non-shattering failure mode)		25kA
Energy	2 Long duration impulses	4.1kJ/kVU _c
Service conditions	Ambient temperature	- 60°C to + 60°C

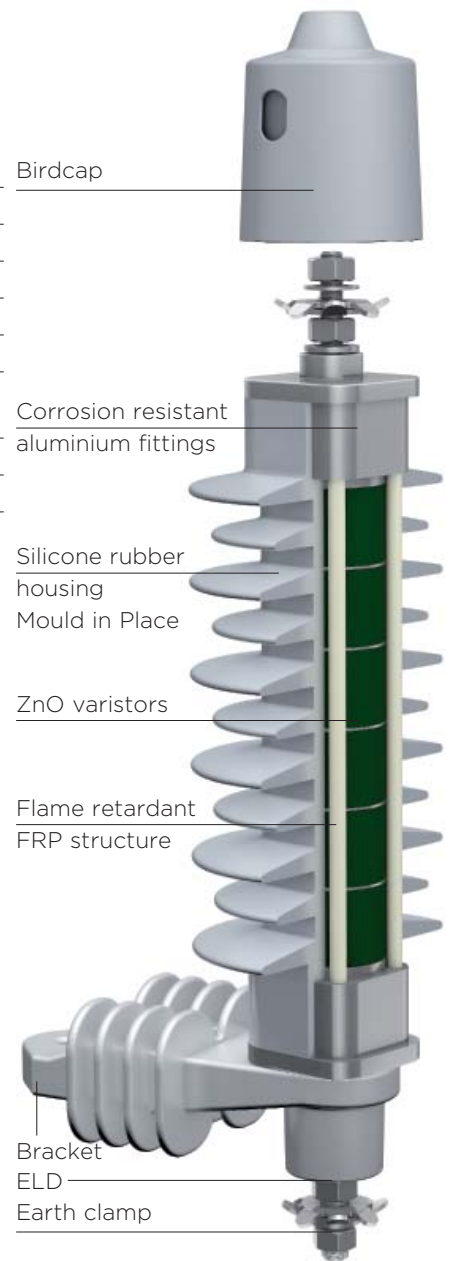

Temporary overvoltage (TOV) of OCP1 with prior energy

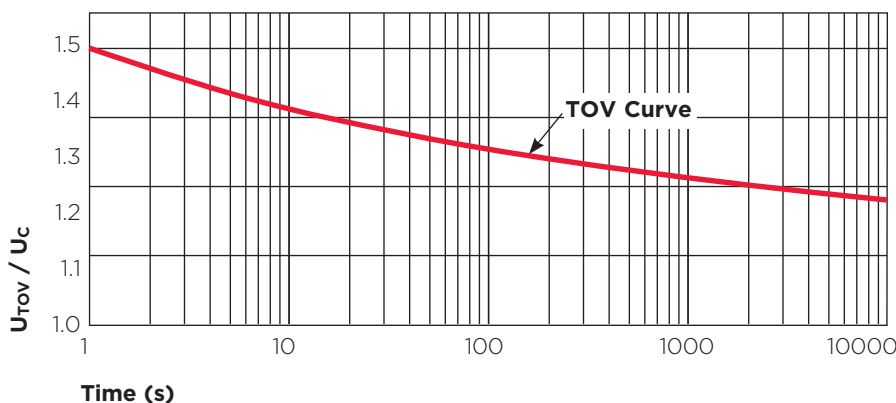

Temperature of samples (pre-heated): 60° C according to IEC 60099-4. TOV Curve applies to an arrester which has a pre-stress applied prior to TOV verification. This pre-stress is equivalent to one high current impulse of 100kA, 4/10µs as per the operating duty test.

U_{TOV} = TOV withstand voltage;
U_c = continuous operating voltage

OCPI Standard electrical data

OCPI	U continuous kV(r.m.s)	U rated kV(r.m.s)	U residual in kV when tested to the following impulse waveforms					
			Lightning (8/20µs)			Steep lightning (1/20µs)		Switching (30/60µs)
			5kA	10kA	20kA	10kA	125A	500A
3	3	3.75	9.77	10.37	11.48	11.28	7.81	8.08
4	4	5	13.03	13.83	15.31	15.04	10.42	10.77
5	5	6.25	16.29	17.29	19.14	18.8	13.02	13.46
6	6	7.5	19.55	20.75	22.97	22.56	15.62	16.15
8	8	10	26.06	27.66	30.62	30.08	20.83	21.54
9	9	11.25	29.32	31.12	34.45	33.84	23.44	24.23
10	10	12.5	32.58	34.58	38.28	37.6	26.04	26.92
12	12	15	39.1	41.5	45.94	45.12	31.25	32.3
15	15	18.75	48.87	51.87	57.42	56.4	39.06	40.38
18	18	22.5	58.64	62.24	68.9	67.68	46.87	48.46
20	20	25	65.16	69.16	76.56	75.2	52.08	53.84
21	21	26.25	68.42	72.62	80.39	78.96	54.68	56.53
22	22	27.5	71.68	76.08	84.22	82.72	57.29	59.22
24	24	30	78.19	82.99	91.87	90.24	62.5	64.61
29	29	36.35	94.48	100.28	111	109.04	75.52	78.07

Uc: Continuous Voltage; Ur: Rated Voltage; Ures: Residual Voltage

OCPI-xxS Standard housing parameters

OCPI	Sheds	Impulse voltage 1.2/50µs (kV)	Power frequency withstand voltage, wet (kV)	Flash over distance (mm)	Creepage length (mm)	Height L (mm)	Weight (approx) (kg)
03	5	145	47	176	380	183	1.8
04	5	145	47	176	380	183	1.8
05	5	145	47	176	380	183	1.8
06	5	145	47	176	380	183	1.8
08	5	145	47	176	380	183	1.8
09	5	145	47	176	380	183	1.8
10	5	145	47	176	380	183	1.8
12	5	145	47	176	380	183	1.8
15	7	165	57	214	505	220	2.2
18	9	180	70	254	632	260	2.65
20	9	180	70	254	632	260	2.65
21	11	200	80	293	758	299	2.1
22	11	200	80	293	758	299	2.1
24	11	200	80	293	758	299	2.1
29	13	230	95	334	885	340	3.4

OCPI-xxL Extended housing parameters

OCPI	Sheds	Impulse voltage 1.2/50µs (kV)	Power frequency withstand voltage, wet (kV)	Flash over distance (mm)	Creepage length (mm)	Height L (mm)	Weight (approx) (kg)
03	7	165	57	214	505	220	2.2
04	7	165	57	214	505	220	2.2
05	7	165	57	214	505	220	2.2
06	7	165	57	214	505	220	2.2
08	7	165	57	214	505	220	2.2
09	7	165	57	214	505	220	2.2
10	7	165	57	214	505	220	2.2
12	7	165	57	214	505	220	2.2
15	9	180	70	254	632	260	2.65
18	11	200	80	293	758	299	3
20	11	200	80	293	758	299	3
21	13	230	95	334	885	340	3.4
22	13	230	95	334	885	340	3.4
24	13	230	95	334	885	340	3.4

Tested in accordance with IEC 60099-4

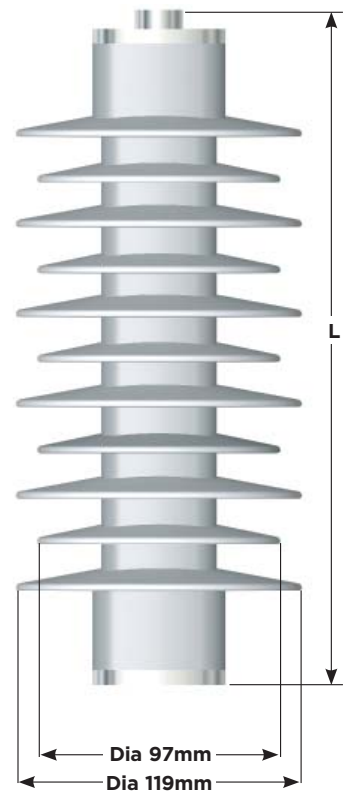

Notes:

Mechanical strength data

Cantilever	Nm	350
Tensile	kN	2
Torque	Nm	50

For accessory and ordering information, please refer to page 14

OCP2 Open Cage Polymeric Surge Arresters - Class 2

Application

Protection of MV networks, sensitive equipment and substations from lightning and switching surge related over-voltages in areas with relatively high iso-keranic levels.

Generic technical data

OCP2 S/L series		3-29kV U _c
Rated discharge current (8/20µs)		10kA
Line discharge class 2 according to		IEC 60099-4
Operating duty impulse withstand current (4/10µs)		100kA
Long duration current impulse (2000µs)		530A
High current short circuit: (pre-failing method) (Safe non-shattering failure mode)		40kA
Energy	2 Long duration impulses	6.0kJ/kVU _c
Service conditions	Ambient temperature	- 60°C to + 60°C

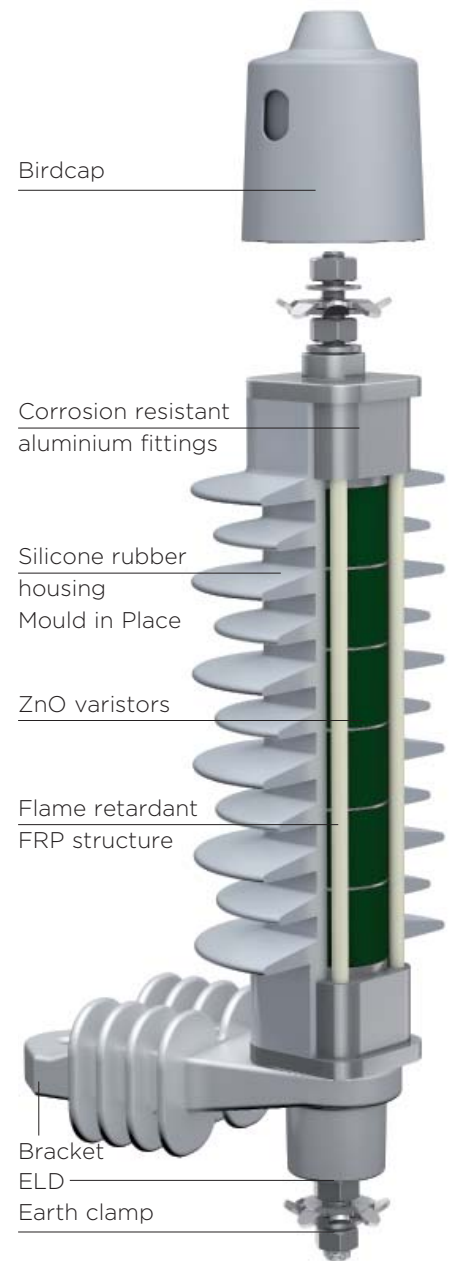

Temporary overvoltage (TOV) of OCP2 with prior energy

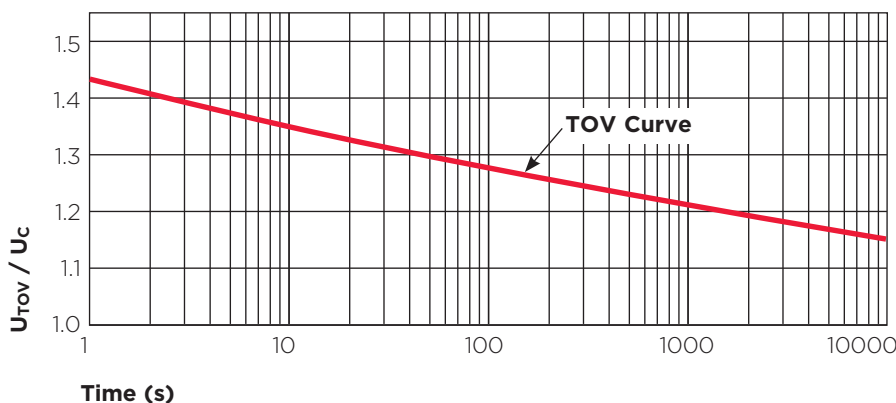

Temperature of samples (pre-heated): 60° C according to IEC 60099-4.
 TOV Curve applies to an arrester which has a pre-stress applied prior to TOV verification. This pre-stress is equivalent to two long duration current impulses having duration of 2000µs and total energy equal to 6.0 kJ/kV U_c.

U_{TOV} = TOV withstand voltage;
 U_c = continuous operating voltage

OCP2 Standard electrical data

OCP2	U continuous kV(r.m.s)	U rated kV(r.m.s)	U residual in kV when tested to the following impulse waveforms					
			Lightning (8/20µs)			Steep lightning (1/20µs)		Switching (30/60µs)
			5kA	10kA	20kA	10kA	125A	500A
3	3	3.75	9.18	9.72	10.84	10.1	7.37	7.76
4	4	5	12.24	12.96	14.46	13.47	9.83	10.35
5	5	6.25	15.3	16.2	18.07	16.84	12.29	12.94
6	6	7.5	18.36	19.44	21.68	20.21	14.75	15.53
8	8	10	24.48	25.92	28.91	26.94	19.66	20.7
9	9	11.25	27.54	29.16	32.53	30.31	22.12	23.29
10	10	12.5	30.6	32.4	36.14	33.68	24.58	25.88
12	12	15	36.72	38.88	43.37	40.42	29.5	31.06
15	15	18.75	45.90	48.6	54.21	50.52	36.87	38.82
18	18	22.5	55.08	58.32	65.05	60.62	44.24	46.58
20	20	25	61.2	64.8	72.28	67.36	49.16	51.76
21	21	26.25	64.26	68.04	75.89	70.73	51.62	54.35
22	22	27.5	67.32	71.28	79.51	74.1	54.08	56.94
24	24	30	73.44	77.76	86.74	80.83	58.99	62.11
29	29	36.35	88.74	93.96	104.81	97.67	71.28	75.05

Uc: Continous Voltage; Ur: Rated Voltage; Ures: Residual Voltage

OCP2-xxS Standard housing parameters

OCP2	Sheds	Impulse voltage 1.2/50µs (kV)	Power frequency withstand voltage, wet (kV)	Flash over distance (mm)	Creepage length (mm)	Height L (mm)	Weight (approx) (kg)
03	5	145	47	176	380	183	1.8
04	5	145	47	176	380	183	1.8
05	5	145	47	176	380	183	1.8
06	5	145	47	176	380	183	1.8
08	5	145	47	176	380	183	1.8
09	5	145	47	176	380	183	1.8
10	5	145	47	176	380	183	1.8
12	5	145	47	176	380	183	1.8
15	7	165	57	214	505	220	2.2
18	9	180	70	254	632	260	2.65
20	9	180	70	254	632	260	2.65
21	11	200	80	293	758	299	2.1
22	11	200	80	293	758	299	2.1
24	11	200	80	293	758	299	2.1
29	13	230	95	334	885	340	3.4

OCP2-xxL Extended housing parameters

OCP2	Sheds	Impulse voltage 1.2/50µs (kV)	Power frequency withstand voltage, wet (kV)	Flash over distance (mm)	Creepage length (mm)	Height L (mm)	Weight (approx) (kg)
03	7	165	57	214	505	220	2.2
04	7	165	57	214	505	220	2.2
05	7	165	57	214	505	220	2.2
06	7	165	57	214	505	220	2.2
08	7	165	57	214	505	220	2.2
09	7	165	57	214	505	220	2.2
10	7	165	57	214	505	220	2.2
12	7	165	57	214	505	220	2.2
15	9	180	70	254	632	260	2.65
18	11	200	80	293	758	299	3
20	11	200	80	293	758	299	3
21	13	230	95	334	885	340	3.4
22	13	230	95	334	885	340	3.4
24	13	230	95	334	885	340	3.4

Tested in accordance with IEC 60099-4

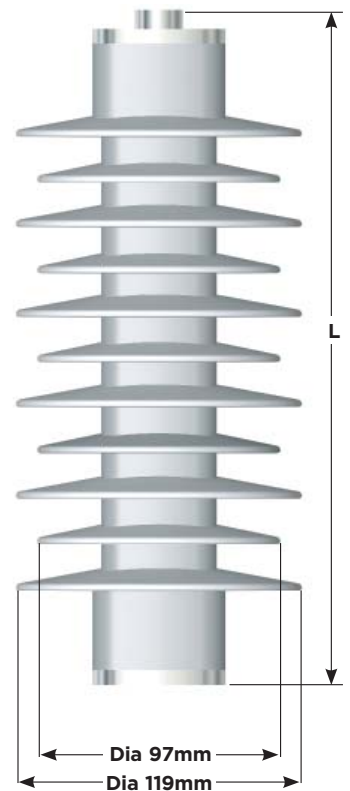

Notes:

Mechanical strength data:

Cantilever	Nm	350
Tensile	kN	2
Torque	Nm	50

For accessory and ordering information, please refer to page 14

OCP2 M/ML Open Cage Polymeric Surge Arresters - Class 2

Generic technical data

OCP2 M/ML series	26-41kV Uc	
Rated discharge current (8/20µs)	10kA	
Line discharge class 2 according to	IEC 60099-4	
Operating duty impulse withstand current (4/10µs)	100kA	
Long duration current impulse (2000µs)	530A	
High current short circuit: (pre-failing method) (Safe non-shattering failure mode)	40kA	
Energy	2 Long duration impulses	6.0kJ/kVUc
Service conditions	Ambient temperature	- 60°C to + 60°C

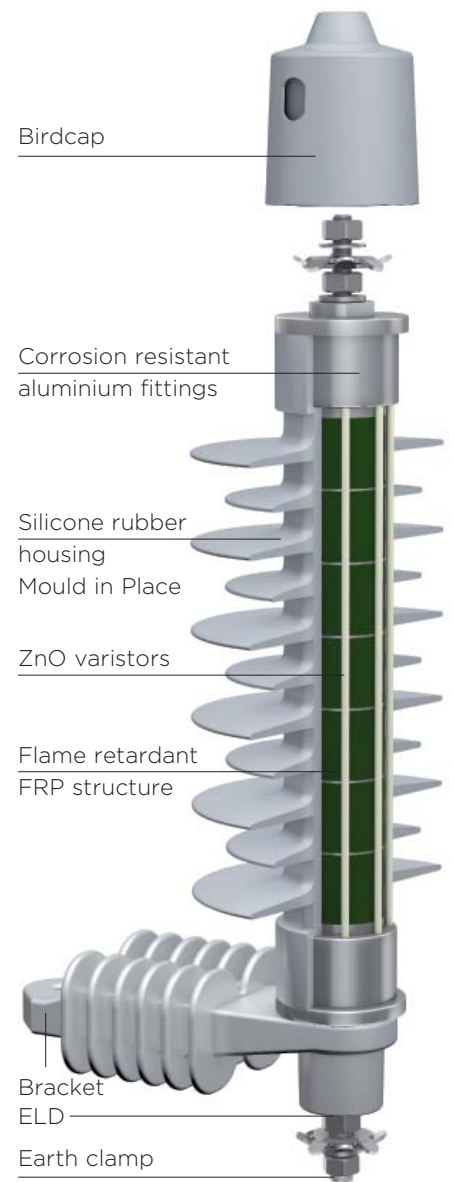
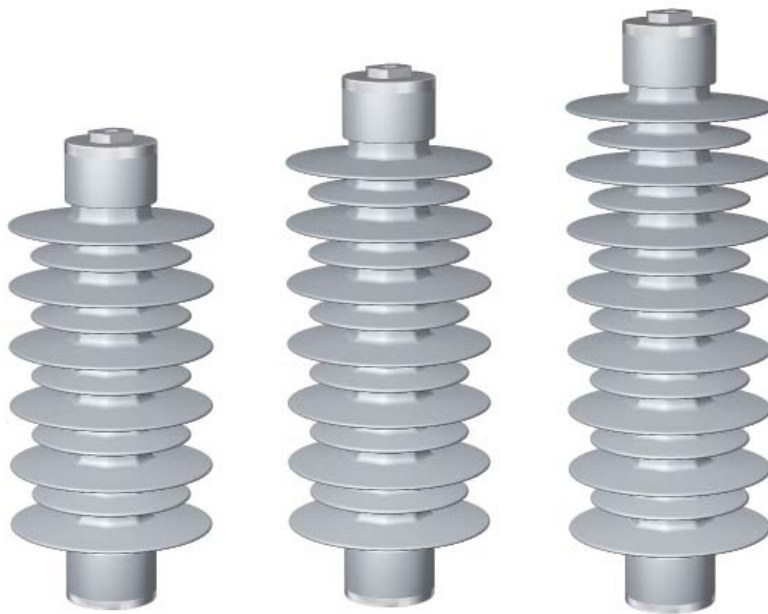

Temporary overvoltage (TOV) of OCP2 with prior energy

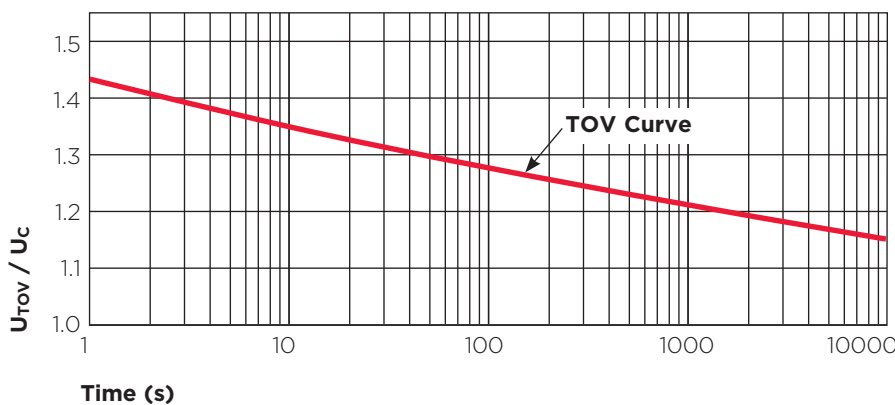

Temperature of samples (pre-heated): 60° C according to IEC 60099-4.
 TOV Curve applies to an arrester which has a pre-stress applied prior to TOV verification. This pre-stress is equivalent to two long duration current impulses having duration of 2000µs and total energy equal to 6.0 kJ/kV Uc.

U_{TOV} = TOV withstand voltage;
 U_c = continuous operating voltage

OCP2-xxM Standard electrical data

OCP2-xxM	U continuous kV(r.m.s)	U rated kV(r.m.s)	U residual in kV when tested to the following impulse waveforms						
			Lightning (8/20µs)			Steep lightning (1/20µs)		Switching (30/60µs)	
			5kA	10kA	20kA	10kA	125A	500A	
26	26	32.5	79.6	84.2	94	87.6	63.9	67.3	
27	27	33.75	82.6	87.5	97.6	90.9	66.4	69.9	
29	29	36.35	88.7	94	104.8	97.9	71.3	75.1	
30	30	37.5	91.8	97.2	108.4	101	73.7	77.6	
33	33	41.25	101	106.9	119.3	111.1	81.1	85.4	
36	36	45	110.2	116.6	130.1	121.2	88.5	93.2	
39	39	48.75	119.3	126.4	140.9	131.4	95.9	100.9	
40	40	50	122.4	129.6	144.6	134.7	98.3	103.5	
41	41	51.25	125.5	132.8	148.2	138.1	100.8	106.1	

Uc: Continuous Voltage; Ur: Rated Voltage; Ures: Residual Voltage

OCP2-xxM Standard housing parameters

OCP2-xxM	Sheds	Impulse voltage 1.2/50µs (kV)	Power frequency withstand voltage, wet (kV)	Flash over distance (mm)	Creepage length (mm)	Height L (mm)	Weight (approx) (kg)
26	11	204	98	339	970	343	3.65
27	11	204	98	339	970	343	3.65
29	11	204	98	339	970	343	3.65
30	11	204	98	339	970	343	3.65
33	13	228	110	378	1125	383	4.15
36	13	228	110	378	1125	383	4.15
39	15	250	122	418	1279	423	4.65
40	15	250	122	418	1279	423	4.65
41	15	250	122	418	1279	423	4.65

OCP2-xxML Extended housing parameters

OCP2-xxML	Sheds	Impulse voltage 1.2/50µs (kV)	Power frequency withstand voltage, wet (kV)	Flash over distance (mm)	Creepage length (mm)	Height L (mm)	Weight (approx) (kg)
26	13	228	110	378	1125	383	4.15
27	13	228	110	378	1125	383	4.15
29	13	228	110	378	1125	383	4.15
30	15	250	122	418	1279	423	4.65
31	15	250	122	418	1279	423	4.65
33	15	250	122	418	1279	423	4.65
36	15	250	122	418	1279	423	4.65

Tested in accordance with IEC 60099-4

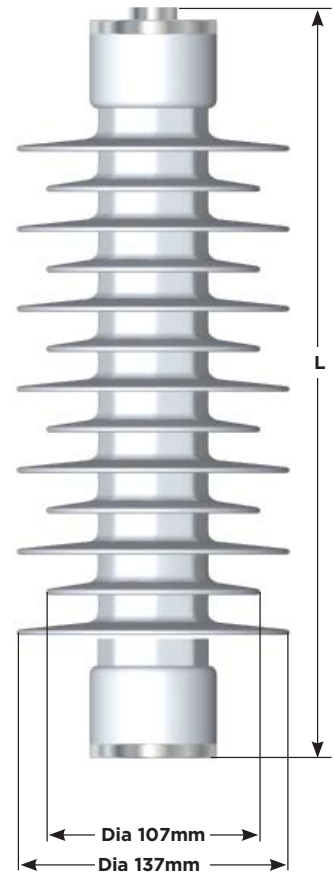

Notes:

Mechanical strength data

Cantilever	Nm	350
Tensile	kN	2
Torque	Nm	50

For accessory and ordering information, please refer to page 14

OCP Series Product Accessories

OCP series naming and order query description:

Example: OCP = "Open Cage Polymeric" OCP1 - 12S - MEL

Line discharge class:
 1 = 10kA, 100kA high current, class 1
 2 = 10kA, 100kA high current, class 2

Uc: 3, 4, 5, 6, 8, 9, 10, 12, 15, 18, 20, 21,
 22, 24, 29, 30, 33, 36, 39, 40, 41

Housing size:
 S / M = standard creepage
 L / ML = extended creepage

Accessory selection
 M = Mounting bracket
 E = Earth connection
 L = Line connection

Minimum clearances following IEC 60071-2 for altitudes up to 1000 m

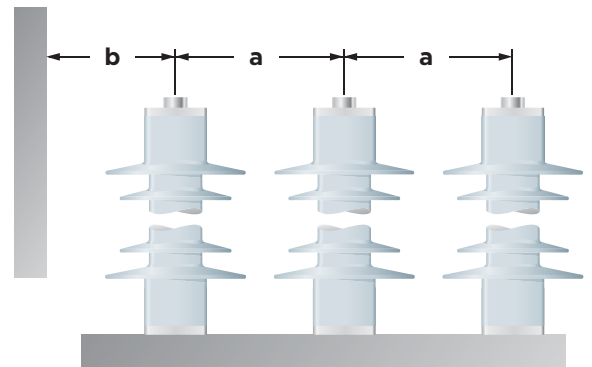

M Mounting accessories

A xx Straight 2 hole mounting bracket	B xx Insulating bracket	C xx DIN metal bracket	N xx No mounting accessories

E Earth lead accessories

x D x Disconnect & M accessory	x E x Disconnect & F accessory	x F x Exposed stud for lug connection	x H x M12 cap screw & spring washer	x L x Exposed stud for 2 lug connection	x M x Exposed stud for line lead connection	x N x Exposed stud. No accessories

L Line lead accessories

xx B Birdcap with F accessory	xx E Birdcap with M accessory	xx F Exposed stud for lug connection	xx H M12 cap screw & spring washer	xx L Exposed stud for 2 lug connection	xx M Exposed stud for line lead connection	xx N Exposed stud. No accessories
xx P S-Clamp	xx Q L-Clamp					

OCP - 12 -

Additional accessory options available on request. Please contact: surgearresters@te.com with your specific requirement. All fasteners M12 unless stated

Product Accessories (Dimensions)

Line & earth F accessories
Stainless steel lug connection

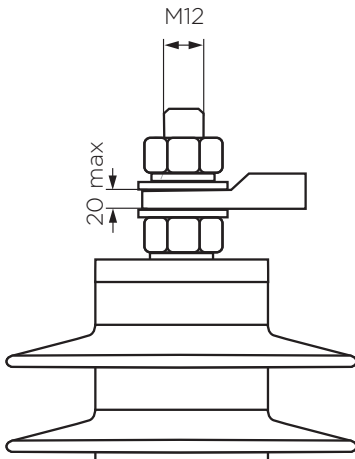

Line & earth H accessories
Cap screw connection

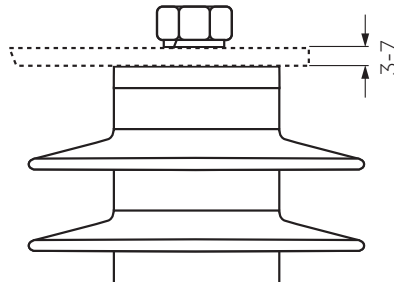

Line & earth M accessories
Stainless steel line lead connection,
(up to diameter 16mm)

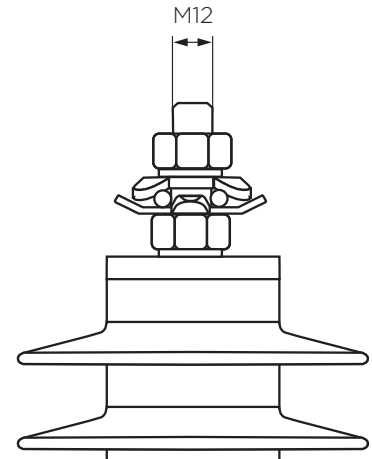

Line & earth O accessories
No accessories

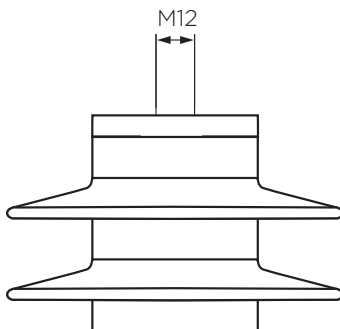

Line P accessory
Stainless steel S clamp,
(up to diameter 8-17mm)

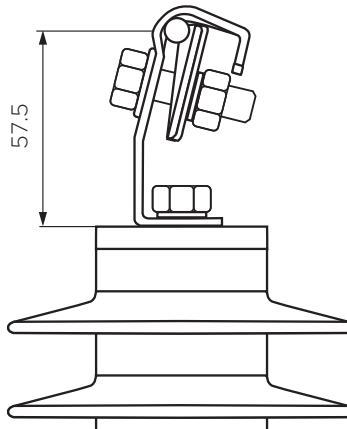

Line Q accessory
Stainless steel Q clamp,
(up to diameter 8-16mm)

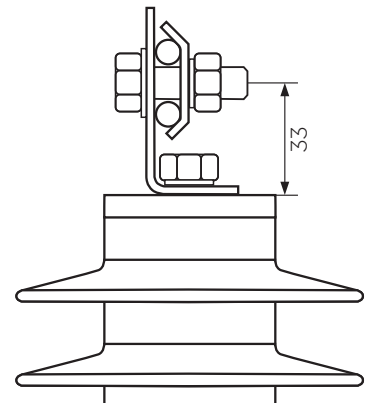

Mounting A accessory
Galvanized steel Straight 2hole
mounting metal bracket

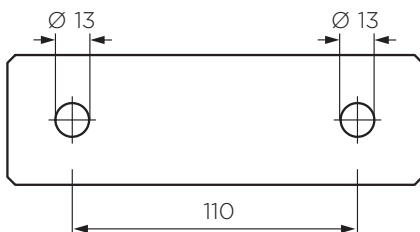

Mounting E accessory
Galvanized steel DIN metal bracket

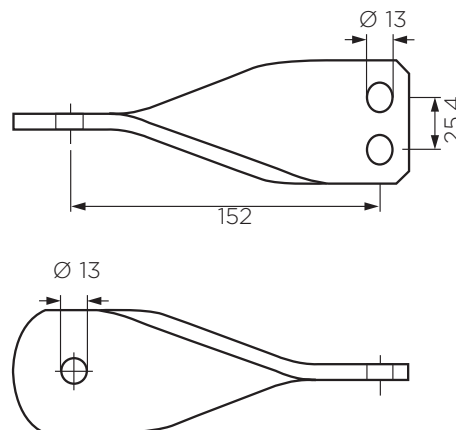

All dimensions in mm.

For addition accessory options,
please contact support team at:
surgearresters@te.com

Product Accessories (Dimensions)

Line B & E accessories
Tracking and erosion resistant
bird protection cover

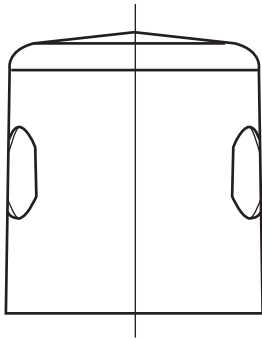

Line D & E accessories
Earth lead disconnect

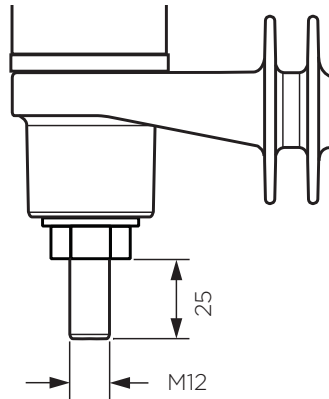

Mounting C accessory
Stainless steel DIN metal bracket

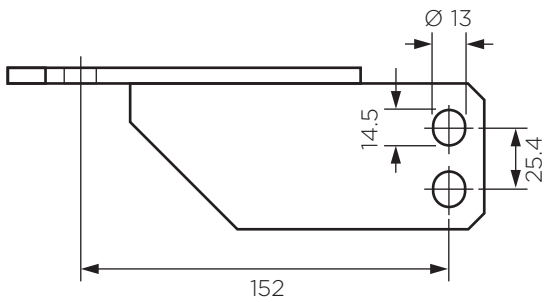

Galvanized steel NEMA cross arm mounting bracket

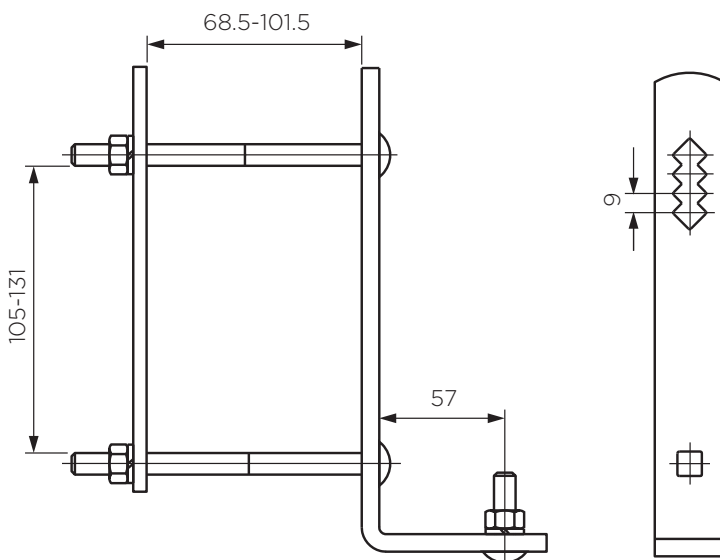

All dimensions in mm.

For addition accessory options,
please contact support team at:
surgearresters@te.com

Product Accessories (Dimensions)

**Mounting B accessory
Insulating brackets**

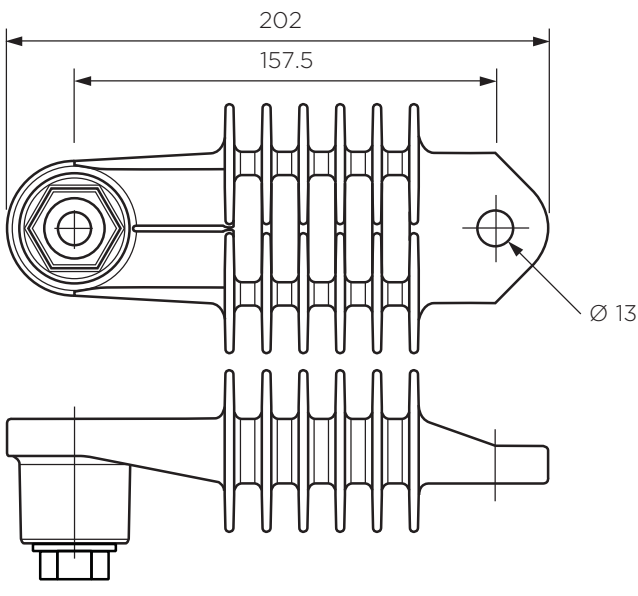
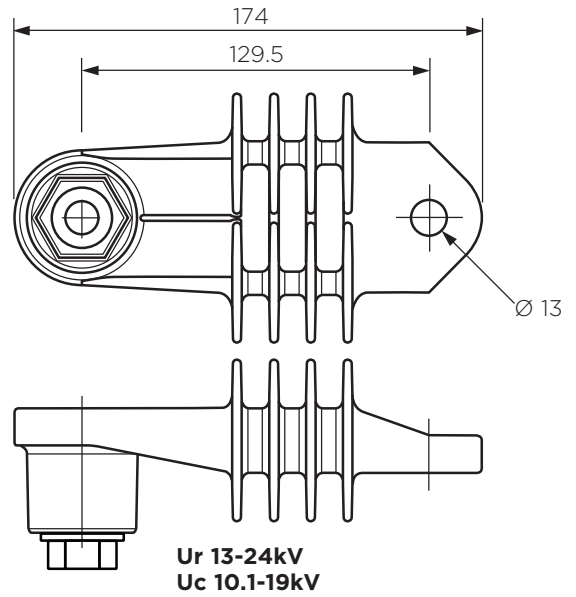
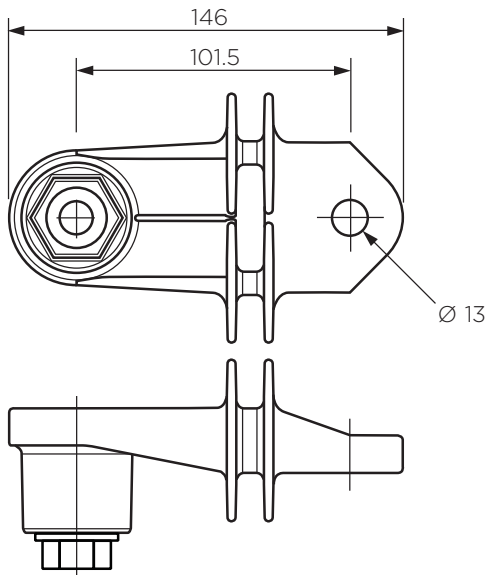

All dimensions in mm.

For addition accessory options,
please contact support team at:
surgearresters@te.com

CLX Surge Arresters for Covered Conductors

Protection system CLX for medium-voltage covered conductor overhead lines

An absolute must when covered conductor systems are used, CLX prevents covered conductors from melting and falling down to earth when lightning strikes generating overvoltages in overhead lines. CLX guides the lightning discharge current to ground, preventing the insulator from flashing over and stops the high energy of the power frequency follow-on current. In addition, the CLX protected overhead lines should see a considerable reduction in power supply interruptions

during storms. This makes it attractive also for bare conductor distribution systems. Even in case of accidental bridging CLX will not cause a phase-to-ground fault. The CLX device contains a Metal Oxide Resistive Element and an external series gap to isolate the Metal Oxide Resistive Element from the system. The CLX device is installed next to the line / post insulators and can be adapted to most system applications. The series gap will be realized by different brackets, electrodes and connectors. TE Connectivity offers engineering support to optimize the use of CLX.



Generic technical data

CLX-xx series	12-36 kV U _c
Rated discharge current (8/20μs)	10 kA
Operating duty impulse withstand current (4/10μs)	65 kA
High current short circuit: (pre-failing method) (Safe non-shattering failure mode)	25 kA
Service conditions Ambient temperature	- 60°C to + 60°C

Mechanical strength data

Cantilever	250 Nm
Torque	50 Nm

Standard electrical data

CLX	Lightning current impulse 8/20 μs:			Steep lightning current impulse 1/20 μs:		Lightning Impulse Standard: 1.2/50 μs	Spark-over Voltage Steep-wet: 1000 kV/μs
	5 kA	10 kA	20 kA	10 kA			
CLX-12S	29.3	31.5	35.6	34.6	97	175	
CLX-24S	48.9	52.5	59.4	57.6	100	263	
CLX-36S	78.2	84.0	95.0	92.2	130	294	

Metal oxide resistive elements housing parameters

CLX-xxS	Sheds	Impulse voltage 1.2/50μs (kV)	Power frequency withstand voltage, wet (kV)	Flash over distance (mm)	Creepage length (mm)	Height L (mm)	Weight (approx) (kg)
CLX-12S	5	145	47	176	379	183	1.4
CLX-24S	7	165	57	214	503	220	1.65
CLX-36S	11	200	80	293	755	299	2.1

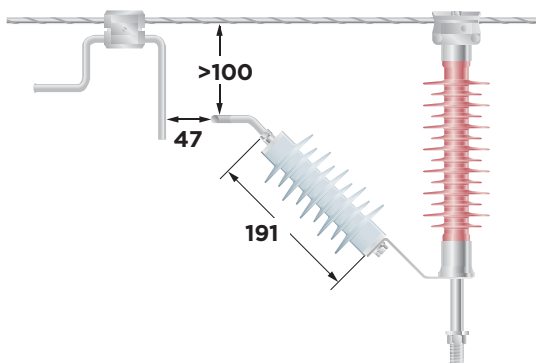

Typical setup for 12 kV rated system Voltage applications

EGLA Externally Gapped Line Arrester

Protection system EGLA for medium-voltage transformer overhead lines

This type of surge arresters is designed to protect the insulator assembly at transformers from the lightning over-voltages. It is connected in parallel to the insulator assembly. It is defined as a device that contains a non-linear metal oxide resistor element in its arrester body (EGLA) and an external

series gap to isolate the EGLA from the system. The protection is accomplished by raising the spark-over level of the external series gap to a level that isolates the arrester from power frequency overvoltages and from the worst case switching overvoltages expected on the line which it is applied. The external series gap acts as an isolating apparatus in the event of arrester body failure.



Without EGLA

Protecting the network from an overvoltage without EGLA can result in a temporary loss of power. The duration of power loss depends on the current protection settings.

The pictures below show different constructions of the EGLA system.

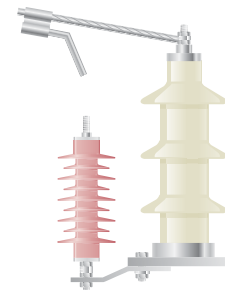
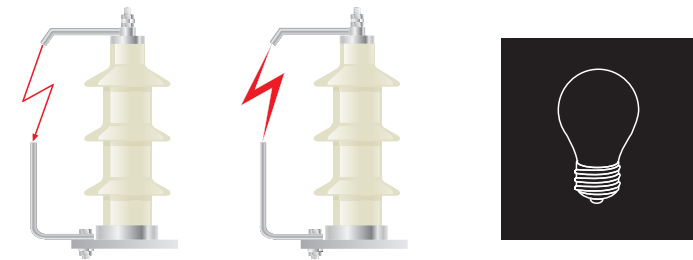

With EGLA

Lightning protection with the EGLA arrester. The EGLA will maintain the integrity of the network.

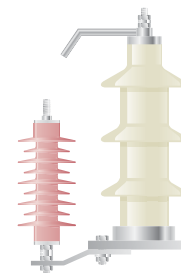
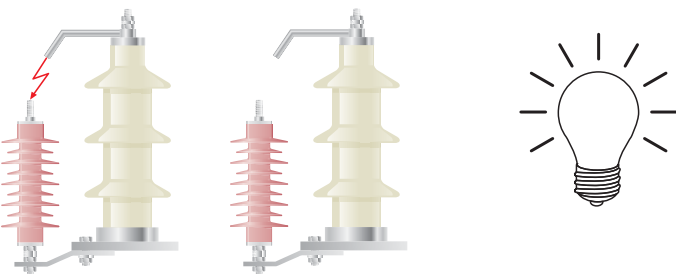

10 kV System

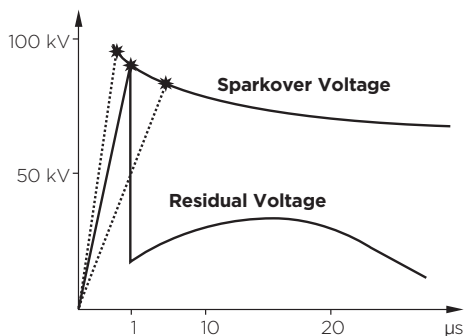

20 kV System

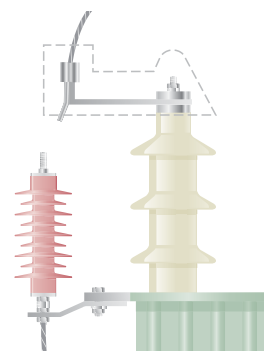
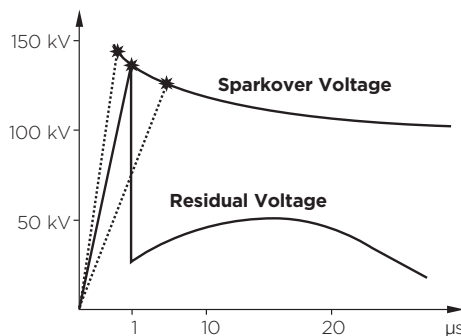

TVC Transient Voltage Clampers

Introduction

In the UK where severe lightning is often accompanied by poor pole earthing resistance, the secondary LV distribution system is subjected to high voltage surges due to lightning current seeking alternate ground paths through the low-voltage circuits. The typical mode of failure of a pole mounted transformer is for the low voltage winding to flash over to the transformer tank due to the relatively high voltage developed across the pole earth resistance. The high voltage arrester does not prevent this type of failure. However, to remove this source of failure (or back flashover) a TVC may be placed between the neutral bushing and the tank.

What is a transient voltage clamper, TVC

A TVC is used to protect against the internal failure of a pole mounted transformer (PMT) due to “back flashover” between the transformer tank and the LV winding bushing. A “back flashover” on a PMT will cause permanent damage to the transformer internal solid insulation.

Conditions of use

- 1) TVC's are useful when there is very high resistivity pole grounding conditions e.g. hot, sandy, rocky ground. Under these soil conditions an earth resistance of 10 ohms or less may be difficult to achieve; resistance maybe variable throughout the year.
- 2) TVC's are useful when the LV earth “downstream” from the PMT is lower than at the pole earth resistance.
- 3) Best used in conjunction with HV and LV surge arresters (cannot be used instead).

Principle of operation

TVCs incorporate a gapless metal oxide varistor, MOV design that under steady state conditions maintains the line-to-ground voltage across the TVCs terminals. When overvoltages occur, the TVC conducts current to earth, limiting the overvoltage to below the required protection levels. Upon passage of the overvoltage condition, the TVC returns to a highly non-linear steady state condition that conducts very minimal 10's of Hz power current.

Transient Voltage Clampers are designed under the same principle as LV voltage surge arresters; however applications are more specific.



Generic technical data

TVC-1	4.8 kV U _c / 6 kV U _r
Rated discharge current (8/20μs)	5 kA
Operating duty impulse withstand current (4/10μs)	65 kA
High current short circuit (pre-failing method) (Safe non-shattering failure mode)	25 kA
Service conditions Ambient temperature	- 40°C to + 40°C

Current-voltage characterisitc for ZnO varistor

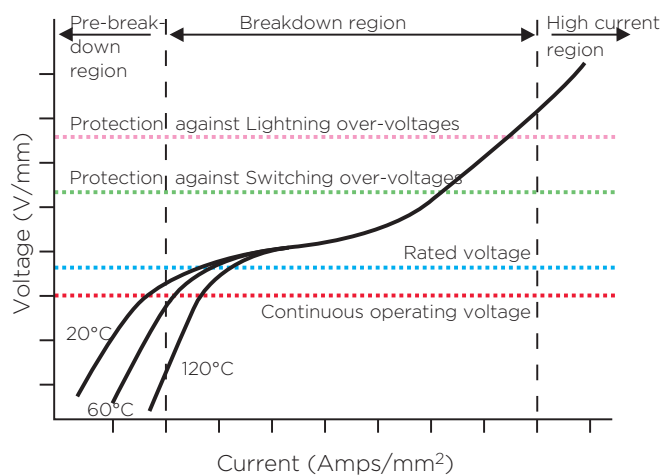

SPG4 Spark Gap Surge Arresters

The Bowthorpe EMP SPG4 Spark Gap is designed for use with traction circuits to provide virtually instantaneous protection of both equipment and personnel from power system faults. The unit also provides protection against lightning generated voltages which would otherwise cause damage to signalling and cable circuits.

The SPG4 is constructed in stainless steel of rugged design allowing the SPG to be installed in harsh environments such as track side locations without additional weather protection.

Features

- Suitable for use on circuits where standing/induced voltages do not exceed 110v RMS.
- Fast operation – Typical 5 microseconds with 11kA fault current.
- Internal spark gap module unit can be replaced using a special tool after fault current operation.
- Fail safe feature ensures safety to personnel and equipment.
- Service proven performance.
- High internal impedance with low capacitance – does not interfere with track signalling circuits.



Typical applications

- Protection between overhead catenary structure earth and system earth.
- Protection between indirectly earthed systems and system or ground earth.
- Protection of single bonded power cable circuits.
- Protection of intermediate junction on cross bonded power cable systems.
- Protection of cathodic protection power supplies.
- Protection of low voltage DC power supplies.

Technical characteristics

The SPG4 Spark Gap operates to short circuit with power system fault current. All lightning induced overvoltages are passed to earth without permanent connection to earth

Max open circuit voltage	300v RMS
Min spark over voltage 50/60Hz	400v RMS
Max spark over voltage 50/60HZ	900v RMS
0.1 second current carrying capacity	10kA
0.5 second current carrying capacity	5kA
Time to gap short circuit	5 microseconds
High current withstand based on 4/10 microsecond wave	65kA (2 shots)
Number of operations based on 10kA 8/20 microsecond wave	20

Other products and brochures available from TE Energy

<p>Asset protection</p>	<p>Insulation enhancement systems for substations and overhead lines. Designed to prevent unplanned outages due to accidental bridging.</p> <p>Contact us at: assetprotection@te.com</p>	
<p>Low-voltage surge arresters</p>	<p>LV arresters are used to provide protection for LV overhead lines, consumer in-house supplies, distribution transformers and other appliances.</p> <p>Contact us at: surgearresters@te.com</p>	
<p>Medium-voltage surge arresters</p>	<p>Metal oxide varistor distribution arresters for indoor and outdoor applications for protection of overhead lines, DC locomotives and switchgear applications.</p> <p>Contact us at: surgearresters@te.com</p>	
<p>High-voltage surge arresters</p>	<p>Porcelain and polymeric series parallel and single column constructed arresters for protection of transmission systems up to 550 kV.</p> <p>Contact us at: hvsa@te.com</p>	
<p>Polymeric insulators</p>	<p>Insulators and insulating components/housings providing reliable solutions for power utilities and railway customers with installations in high pollution environments and applications up to 400 kV.</p> <p>Contact us at: insulators@te.com</p>	
<p>Porcelain insulators</p>	<p>Insulators for applications up to system voltages of 132 kV. This range of insulators offers a cost-effective solution for low and medium polluted environments.</p> <p>Contact us at: insulators@te.com</p>	

About TE Connectivity

TE Connectivity is a global, \$14 billion company that designs and manufactures approximately 500,000 products that connect and protect the flow of power and data inside the products that touch every aspect of our lives. Our nearly 100,000 employees partner with customers in virtually every industry – from consumer electronics, energy and healthcare, to automotive, aerospace and communication networks – enabling smarter, faster, better technologies to connect products to possibilities.

More information on TE Connectivity can be found at: www.te.com

While TE Connectivity (TE) has made every reasonable effort to ensure the accuracy of the information in this catalog, TE does not guarantee that it is error-free, nor does TE make any other representation, warranty or guarantee that the information is accurate, correct, reliable or current. TE reserves the right to make any adjustments to the information contained herein at any time without notice. TE expressly disclaims all implied warranties regarding the information contained herein, including, but not limited to, any implied warranties of merchantability or fitness for a particular purpose. The dimensions in this catalog are for reference purposes only and are subject to change without notice. Specifications are subject to change without notice. Consult TE for the latest dimensions and design specifications. Bowthorpe EMP, TE Connectivity and TE connectivity (logo) are trademarks. Other logos, product and company names mentioned herein may be trademarks of their respective owners. © 2014 TE Connectivity family of companies. All Rights Reserved

EPP 1098 4/14

TE Energy – innovative and economical solutions for the electrical power industry: cable accessories, connectors & fittings, insulators & insulation, surge arresters, switching equipment, street lighting, power measurement and control.

LV/MV Product Management
TE Connectivity Limerick
International Science Centre
Block 1, University Of Limerick (N.T.P.)
Castletroy
Co. Limerick. Ireland

Phone: + 353 61 470 800
Email: surgearresters@te.com

energy.te.com

