

BILL OF MATERIALS

ITEM	PART NUMBER	DESCRIPTION	QTY
1	CSB3908	7" STRINGING BLOCK AXLE	1
2	CSB3919	7" HELI FRAME INSULATOR PIN	1
3	WSH3928	SPACER WASHER - 3/4" ID x 1 1/4" OD x 3/32" THK	1
4	FHX3923	HEX BOLT - 3/8"-16 x 4" L	1
5	FNL3924	HEX LOCK NUT - 3/8"-16	1
6	SPG3929	7" HELI FRAME GATE SPRING - DOUBLE TORSION	1
7	WSH3927	SPACER WASHER - 21/32" ID x 1 5/16" OD x 5/128" THK	4
8	CSB3903	7" POLISHED ALUMINUM SHEAVE ASSEMBLY	1
9	FRP3926	SLOTTED SPRING PIN - 5/32" x 1 5/8" L	3
10	FRP3925	SLOTTED SPRING PIN - 5/32" x 1 1/8" L	3
11	CSB3920	ISOLATOR, STRINGING BLOCK ATTACHMENT	1
12	SPG3931	7" HELI FRAME GATE LOCK PIN SPRING - COMPRESSION	1
13	CSB3922	LOCK PIN ASSEMBLY	1
14	CSB10799	7" HELI FRAME CASTING FOR ZAB4344	1
15	CSB10800	7" HELI FRAME GATE CASTING FOR ZAB4344	1

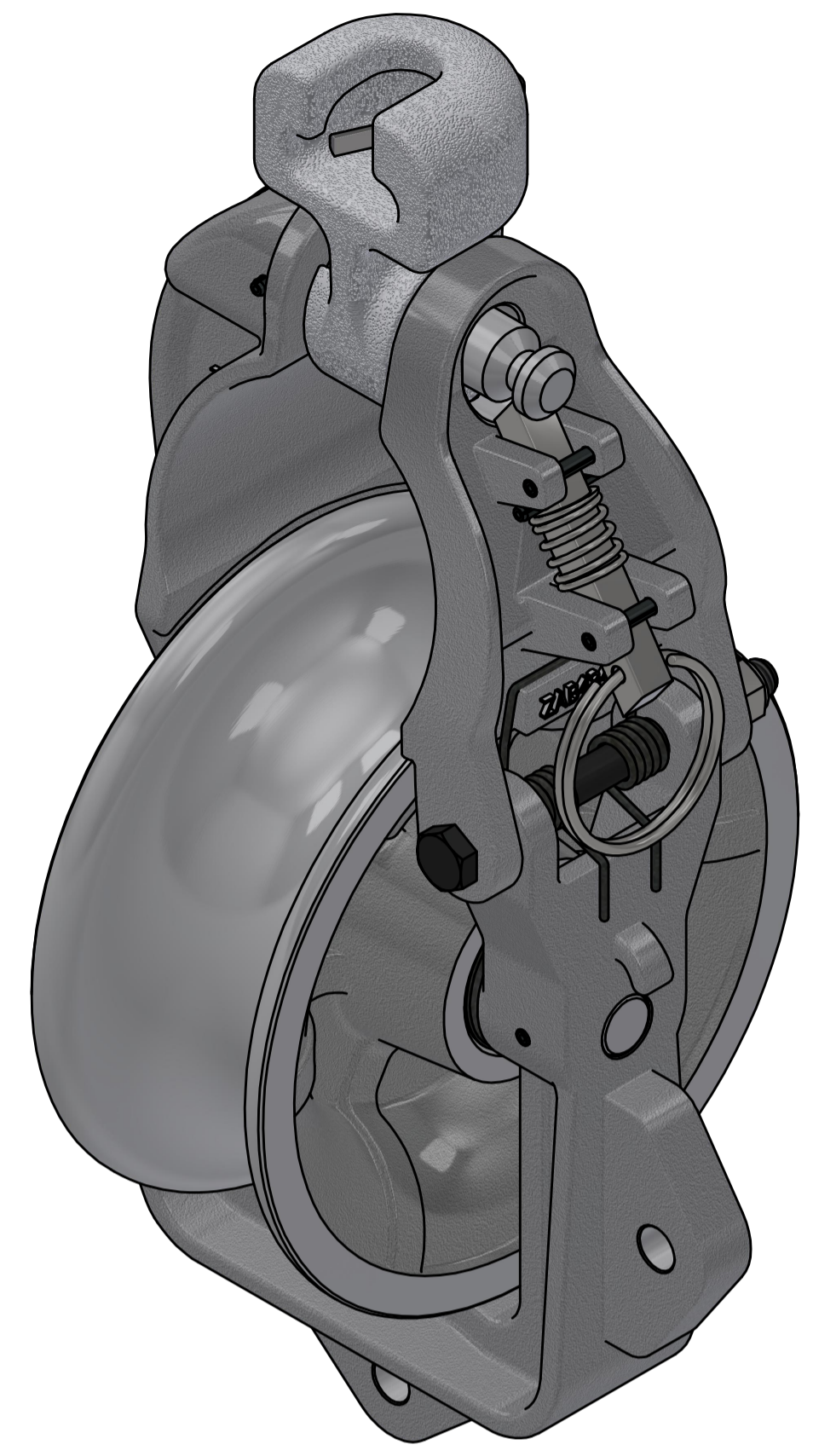
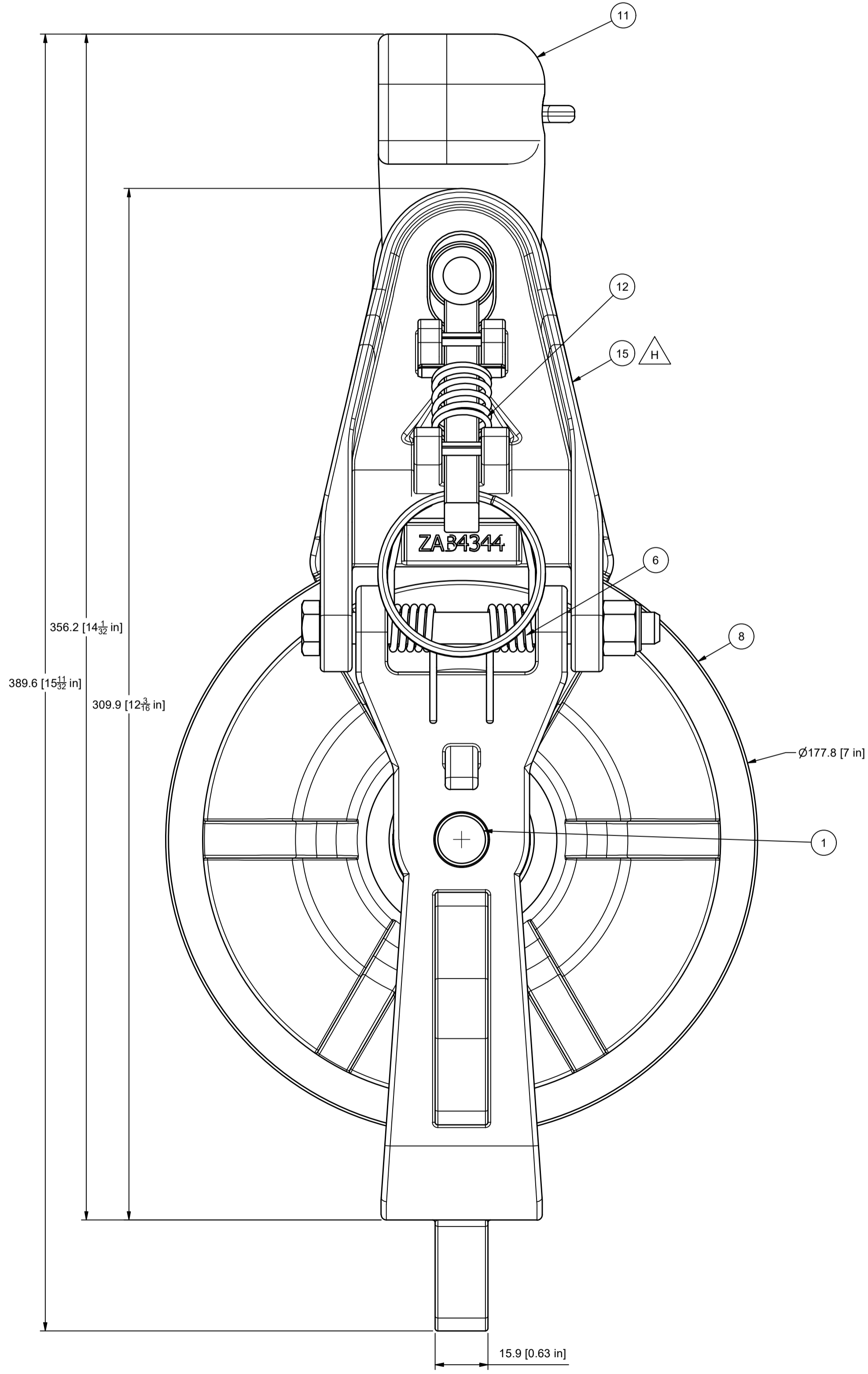
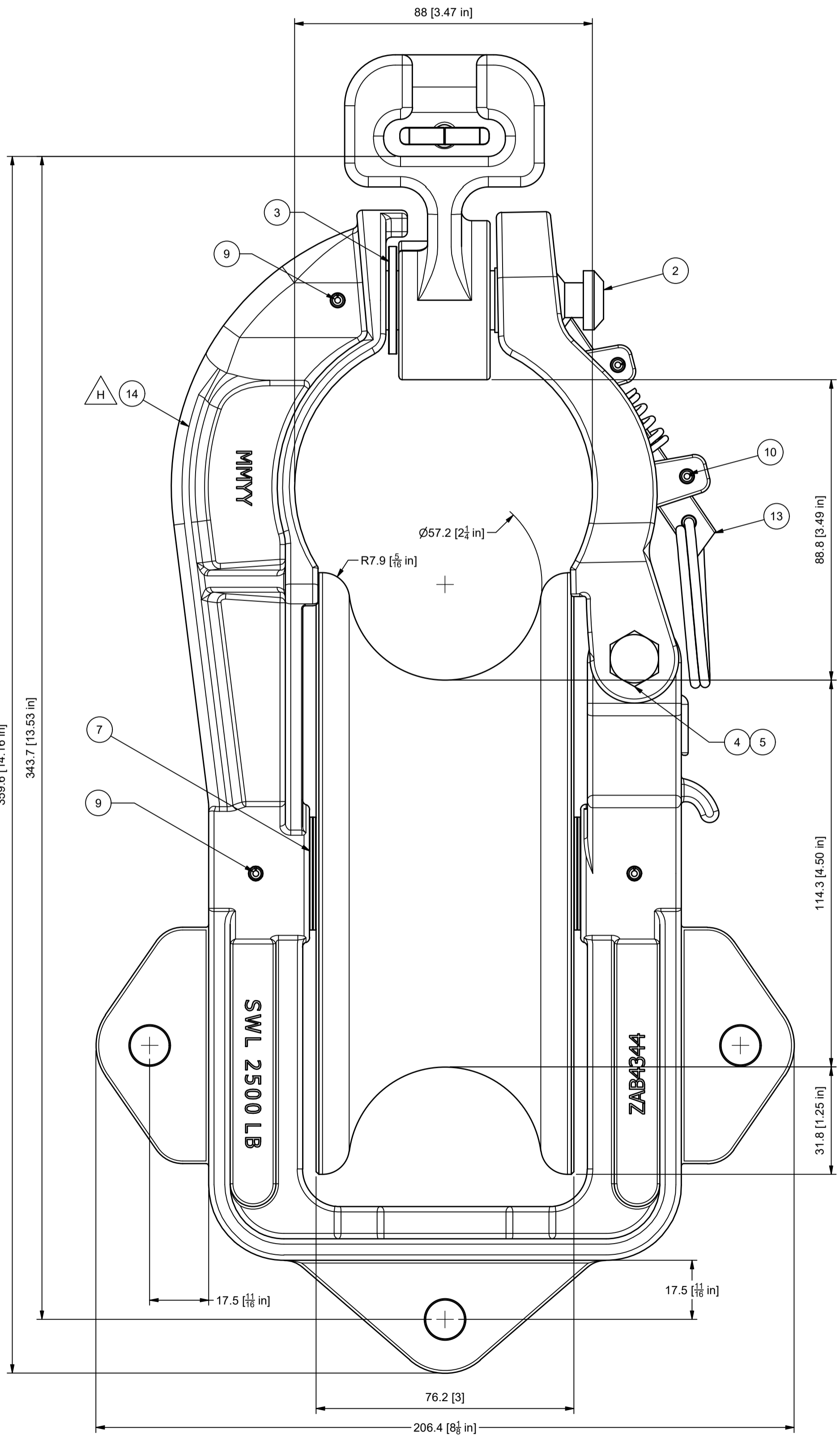

SAFE WORKING LOAD : 2500 LB

REV	DATE	DESCRIPTION	BY
H	12/JULY/22	ECO-001975	AG
G	17/AUG/16	ADDED DIMENSIONS	JWE
F	07/31/14	ADDED SHEAVE OD & GROOVE ID / RAD	TMM
E	2/5/14	UPDATED DWG NO & ADDED OPTIONAL MODEL NOTE	TMM
D	11/25/13	UPDATED DIM TO ADD SLINGCO PART DESCRIPTIONS	TMM
C	9/27/13	UPDATED DIM TO ADD SLINGCO PART NUMBERS	JCG
B	9/17/13	REVISED OVERALL DRAWING AND LAYOUT PER USE	TMM
A	9/5/13	INITIAL RELEASE	JMK

GENERAL MANUFACTURING TOLERANCES EXCEPT WHERE OTHERWISE STATED:		
DIMENSION	MACHINED	FABRICATED
100 AND BELOW	±0.25	±1
OVER 100 UP TO 1000	±0.5	±2
OVER 1000 UP TO 2500	±1.0	±3
OVER 2500	±1.0	±5
HOLE CENTRES TRUE POSITION	±0.5	±1.0
ANGULAR	±0°15'	±1°

ALL DIMENSIONS ARE IN MILLIMETRES UNLESS OTHERWISE STATED.  
 DIMENSIONS, TOLERANCES, SYMBOLS AND SURFACE TEXTURES ARE IN ACCORDANCE WITH BS 8886, UNLESS OTHERWISE STATED.  
 WELD SYMBOLS ARE IN ACCORDANCE WITH BS EN ISO 2553. REMOVE ALL BURRS AND SHARP EDGES.

DO NOT SCALE  
 IF IN DOUBT ASK

**slingco**

SLINGCO LIMITED  
 GATEWAY BUSINESS PARK,  
 NEW HALL HEY ROAD,  
 RAINTON HALL, BBA 4JG  
 e-mail: sales@slingco.com  
 http://www.slingco.com

SLINGCO AMERICA, INC  
 130 CELTIC BLVD,  
 THYONE, GEORGIA, 30280  
 e-mail: sales@slingco.com  
 http://www.slingco.com

COMPONENT	MASS	STATE	SCALE
N/A	Released	A1	

DRAWN	CHECKED	SCALE
APP	RLC	1 : 1

MATERIAL SPECIFICATION

SURFACE FINISH

PROJECT No  
 PN366

PROJECT  
 7" STRINGING BLOCKS

CUSTOMER

CUSTOMER DRAWING No

TITLE	PART No	REV	SHEET
SLINGCO 7" HELI BLOCK W/ ALUM SHV	ZAB4344	H	1 OF 1

FORM REV 52025 REV 4